

Inédit

CATALOGUE N° 21

JANVIER 1963

H G

SILENCIEUX

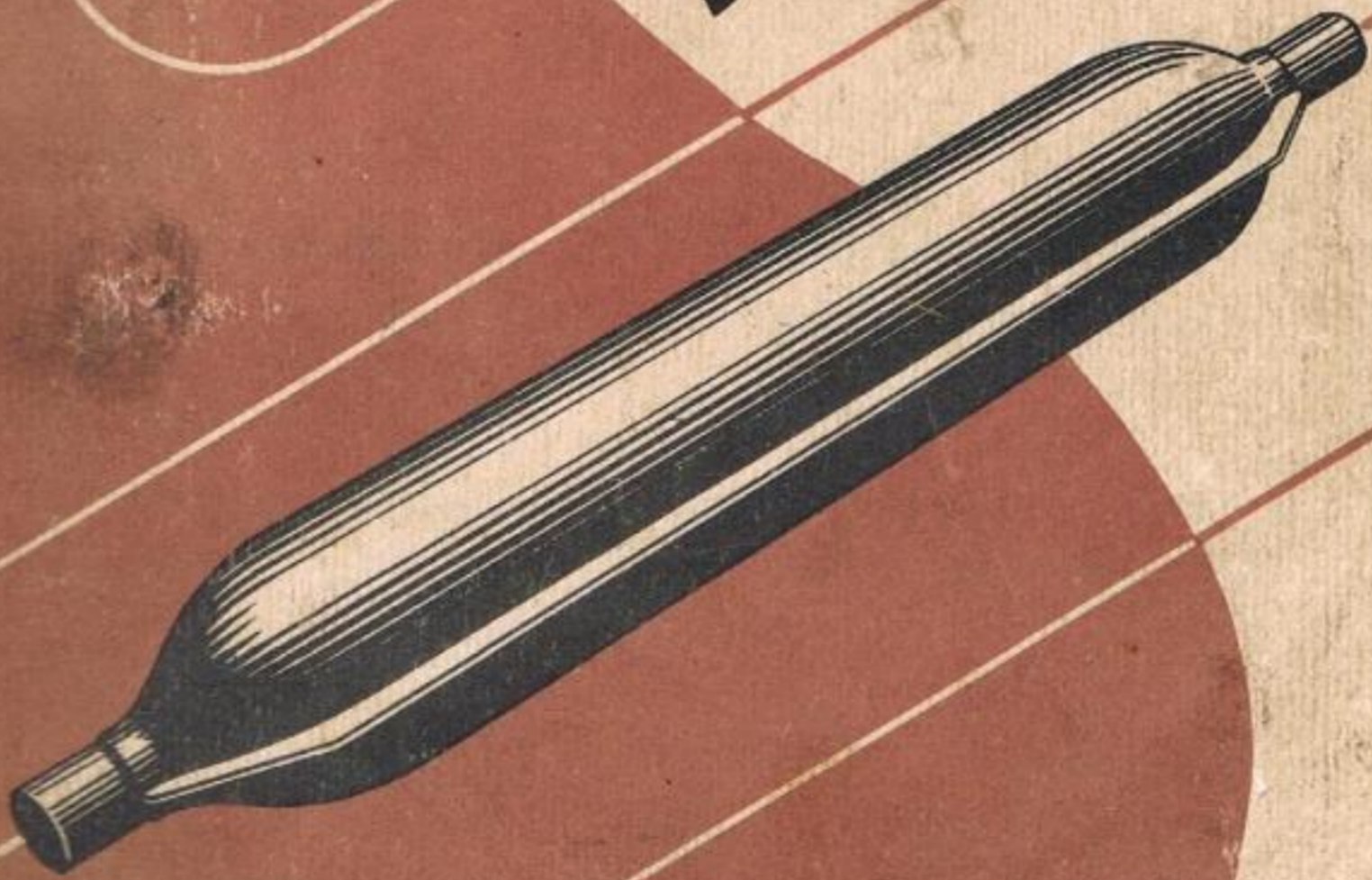

Jean MARIEZ

Représentant

78, B^d Victor-Hugo

NANTES

COFFRES POUR BATTERIES - TUYAUTERIES D'ÉCHAPPEMENT

SILENCIEUX
& COFFRES POUR



TUYAUTERIES
TOUS VÉHICULES

ETS H. GAYTON

SOCIÉTÉ A RESPONSABILITÉ LIMITÉE AU CAPITAL DE 10.000 FR.

R. C. MONTLUÇON 10.447 B
R. P. ALLIER 180
B. I. A. C. F 2708-00

RUE GAMBETTA
DOYET
(ALLIER) FRANCE
TÉLÉPHONE 9

C.C.P. CLERMONT-Fd 409-29
TÉLÉG. : GAYTON-DOYET
BOITE POSTALE N° 1

CONDITIONS DE VENTE

COMMANDES -

Nous vous prions de vouloir bien spécifier, très exactement, les numéros des articles désirés.
Les engagements pris par nos représentants ne sont valables qu'après notre confirmation écrite.

TRANSPORTS -

Nos marchandises voyagent toujours aux risques et périls du destinataire, même expédiées en franco de port, et les prix du présent catalogue s'entendent départ DOYET.

CONTROLE A L'ARRIVÉE -

Nous vous invitons expressément à vérifier nos envois avant d'en prendre livraison.
En cas de manquant, veuillez bien faire toutes réserves auprès du transporteur ou de la S.N.C.F.

GARANTIE -

Nous ne sommes tenus qu'au remplacement pur et simple, et sans aucune indemnité, des pièces reconnues défectueuses après examen dans nos ateliers.

COMPTABILITÉ -

Nos factures sont payables à DOYET au comptant. Nous pouvons également consentir l'ouverture d'un compte à 30 jours le 10 du mois suivant par traite domiciliée.

En cas de litige, le Tribunal de MONTLUÇON est seul compétent.

SILENCIEUX HG

Adaptables à

RENAULT N° 92

- 6 CV, KJ, KJ-1, MT, NN, NN-1,2

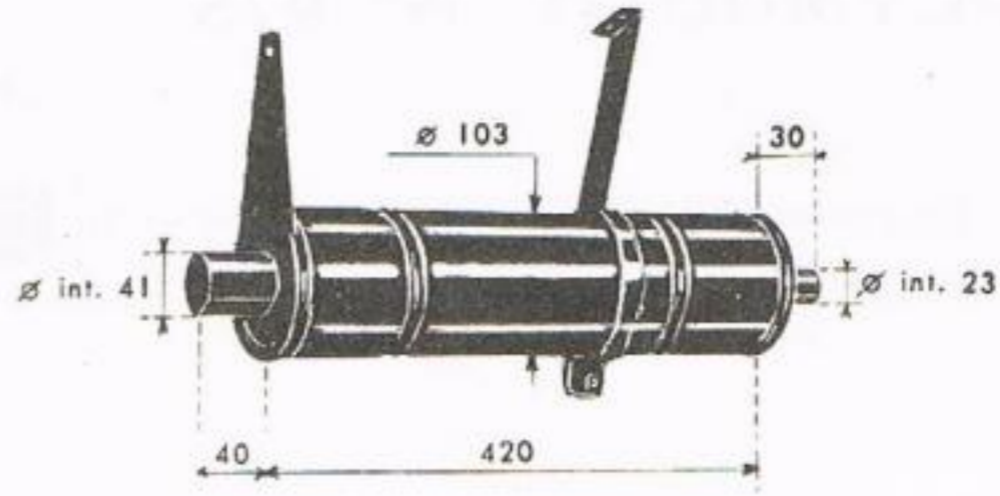

RENAULT N° 65

- 8 CV, MONASIX - RY-2

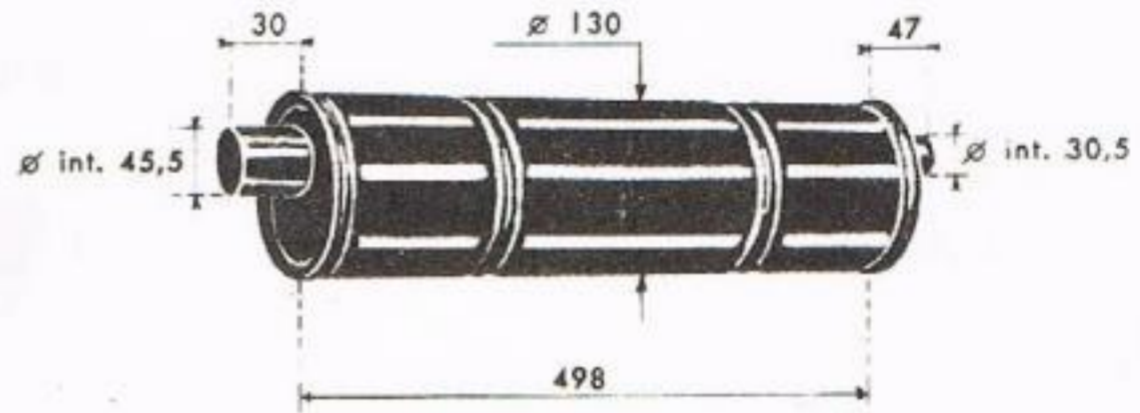

RENAULT N° 441

Tube AV

- 11 CV, OS-1 à 5, PR-1 à 5

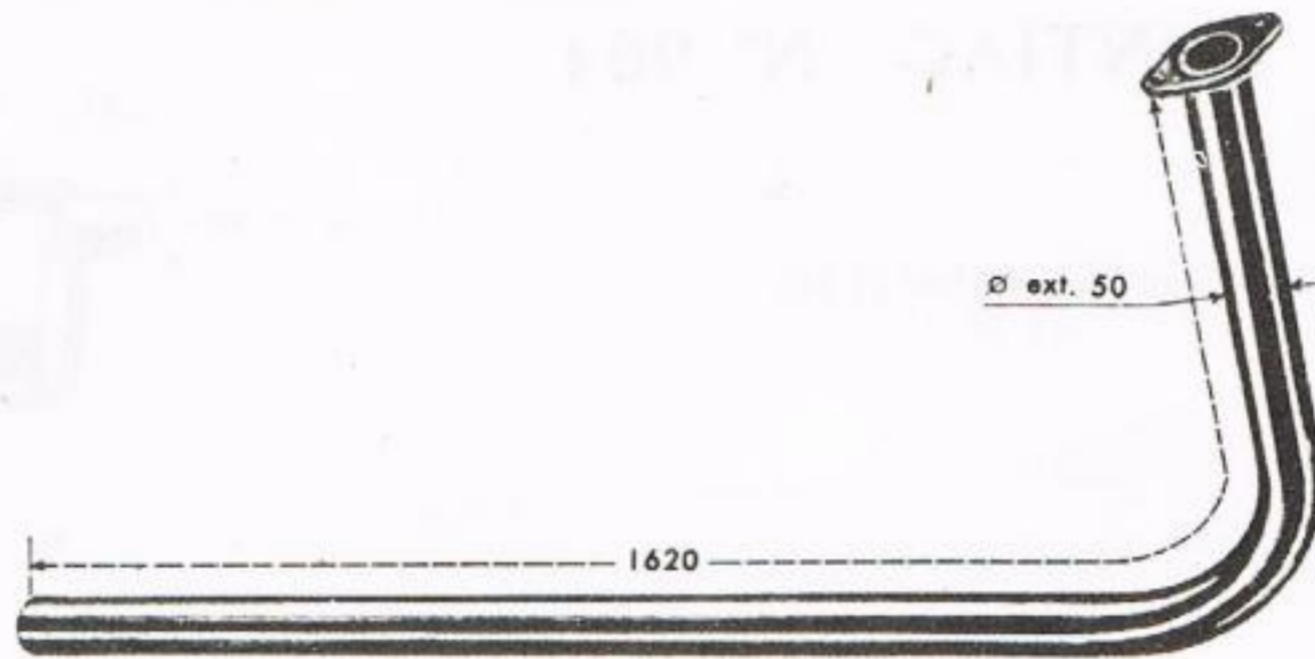

RENAULT N° 39

- 11 CV, OS-1 à 5, PR-1 à 5

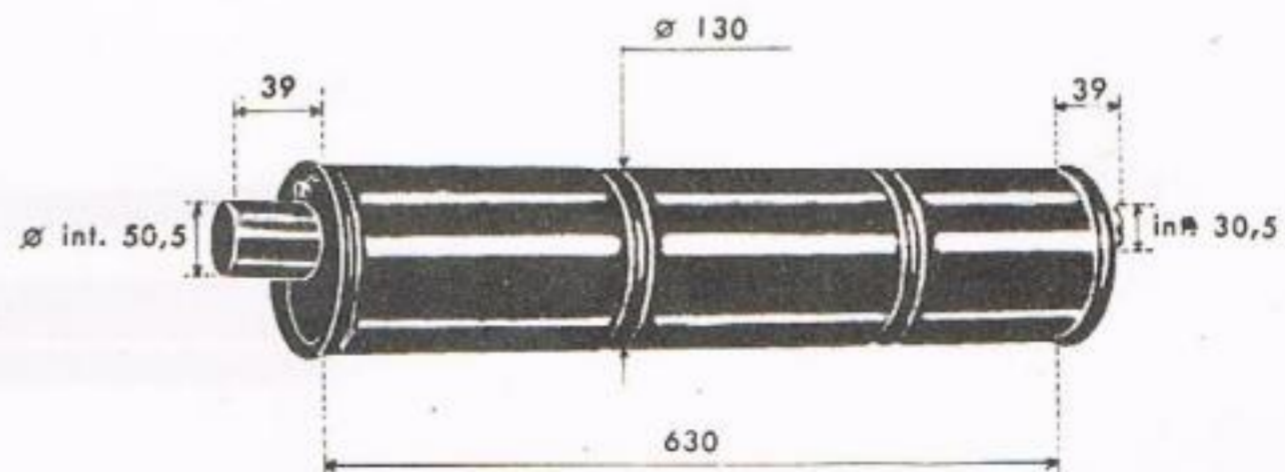

SILENCIEUX HG

Adaptables à

RENAULT N° 39

- 11 CV, KZ-1 à 4

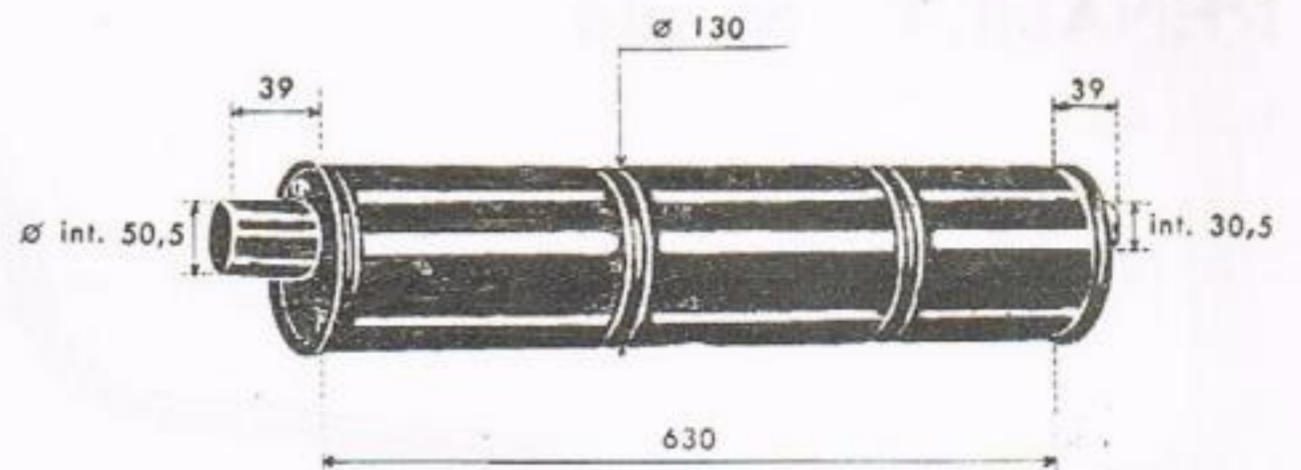

RENAULT N° 184

Tube AR

- 11 CV, KZ-1 à 4

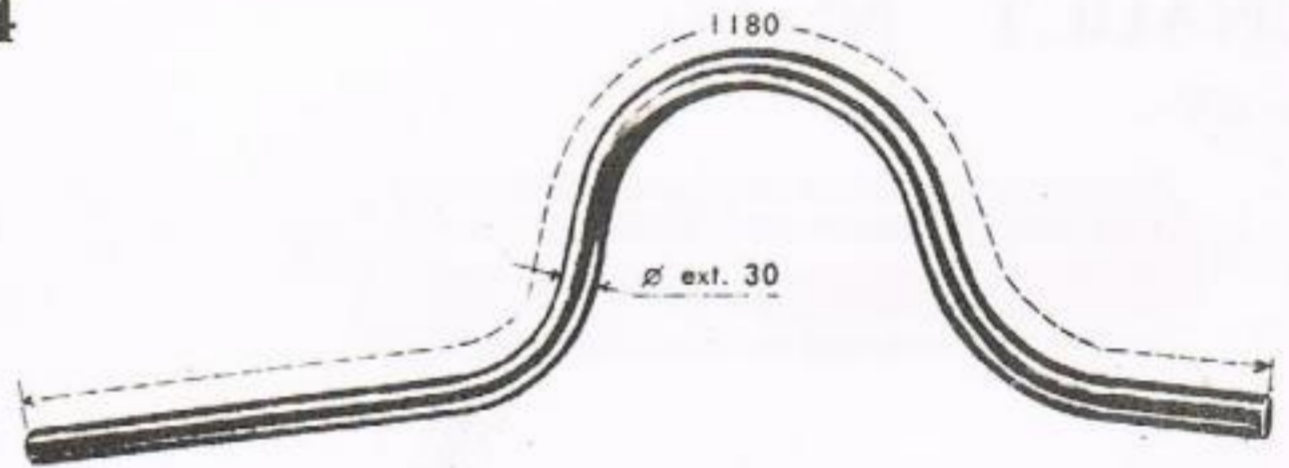

RENAULT N° 391

Tube AV

- 11 CV, KZ-5 à 7



RENAULT N° 39

- 11 CV, KZ-5 à 7

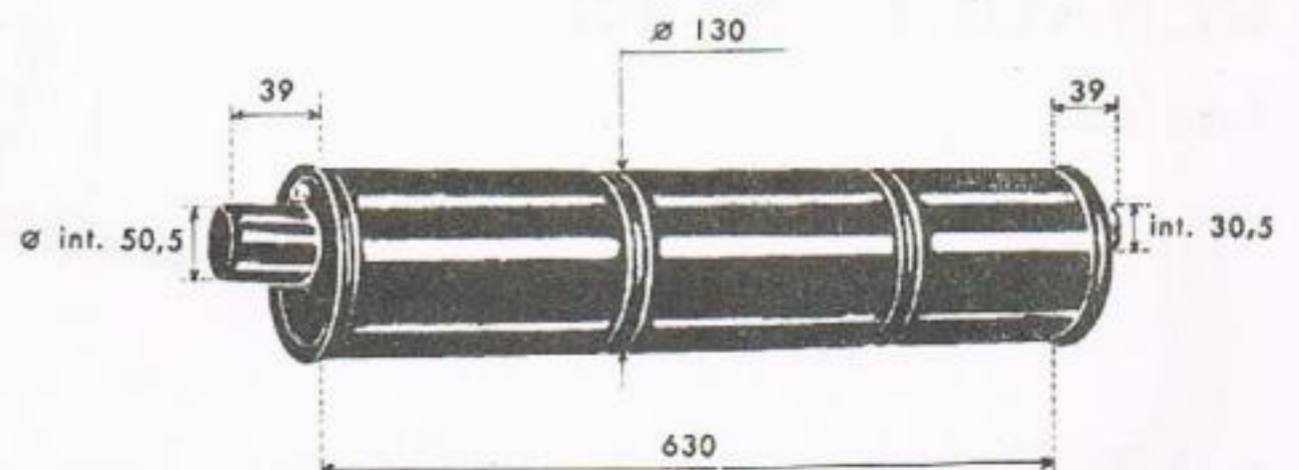

(Voir page 160, tube AR N° 184)

SILENCIEUX HG

Adaptables à

RENAULT N° 184

Tube AR

- 11 CV, KZ-5 à 7

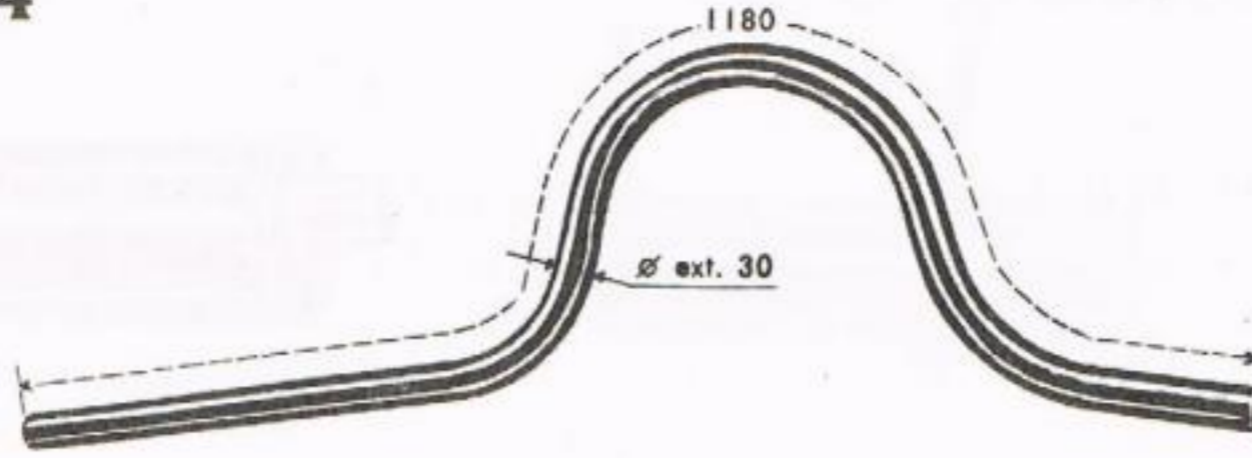

RENAULT N° 381

Tube AV

- 11 CV, KZ-8



RENAULT N° 1001

- 11 CV, KZ-8

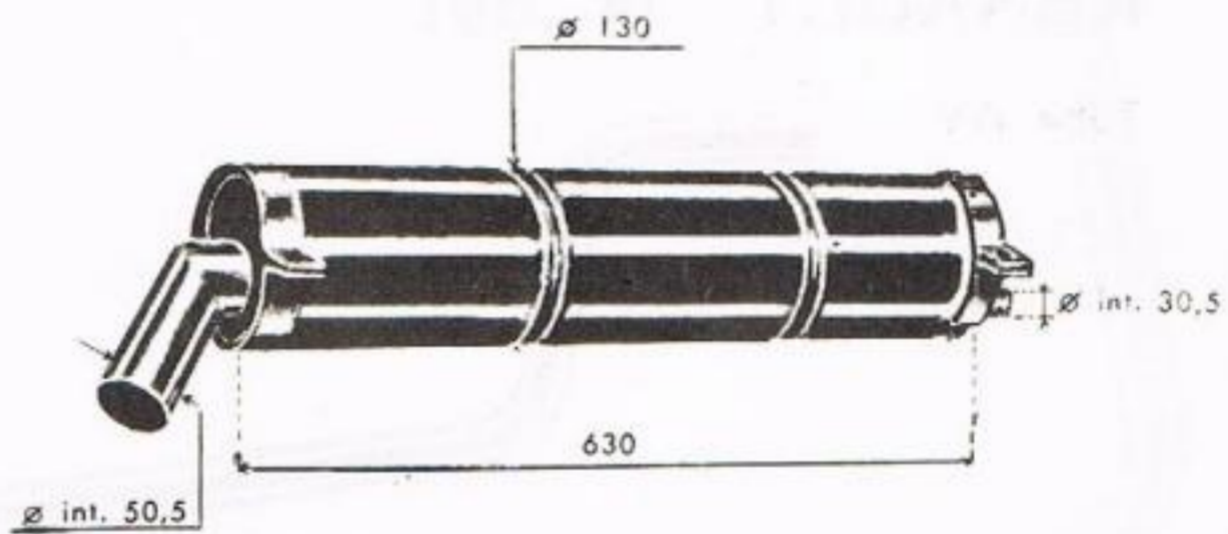

RENAULT N° 191

Tube AR

- 11 CV, KZ-8

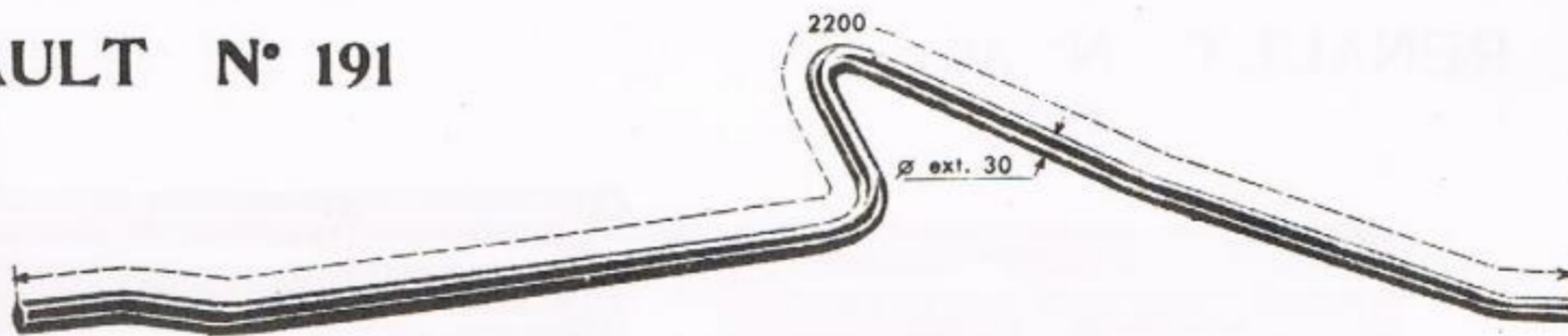

SILENCIEUX HG

Adaptables à

RENAULT N° 401

Tube AV

- 11 CV, KZ-9
(S'adapte sur KZ-9 en raccourcissant la partie droite horizontale)

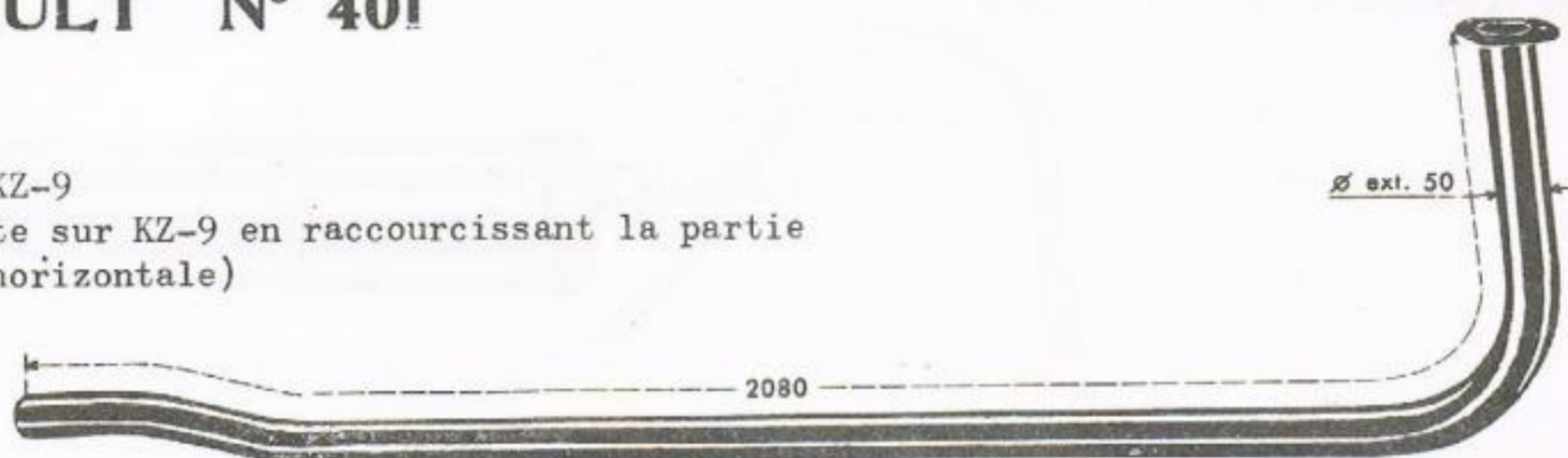

RENAULT N° 39

- 11 CV, KZ-9

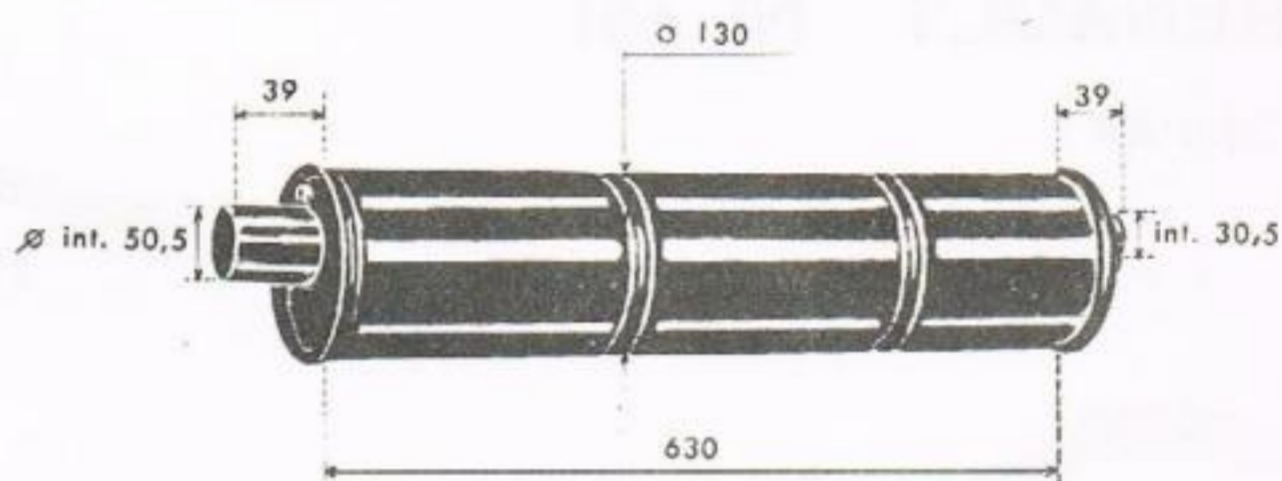

RENAULT N° 281

Tube AR

- 11 CV, KZ-9

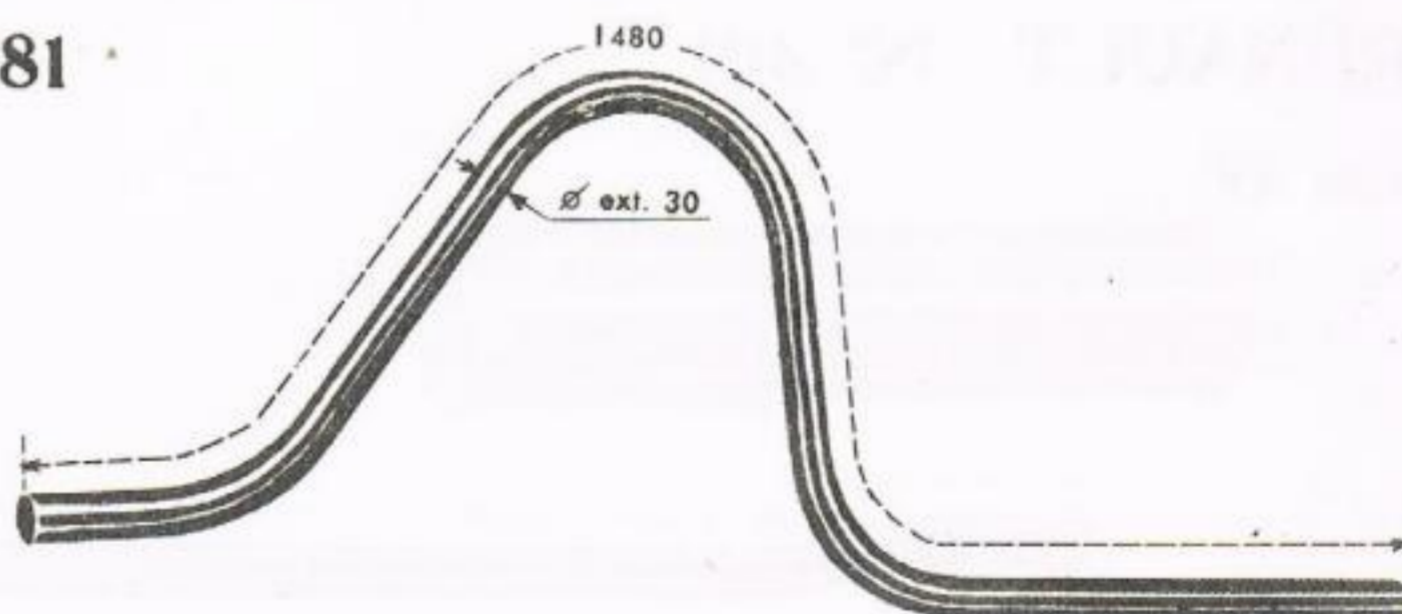

RENAULT N° 401

Tube AV

- 11 CV, KZ-10



(Voir page 162, sil. N° 39 et tube AR N° 481)

SILENCIEUX HG

Adaptables à

RENAULT N° 39

- 11 CV, KZ-10

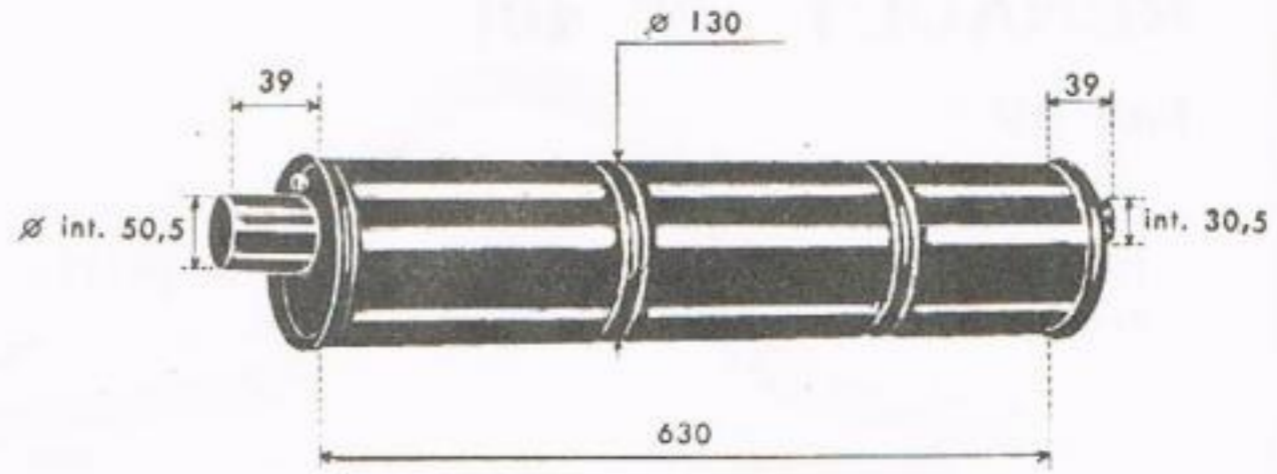

RENAULT N° 481

Tube AR

- 11 CV, KZ-10

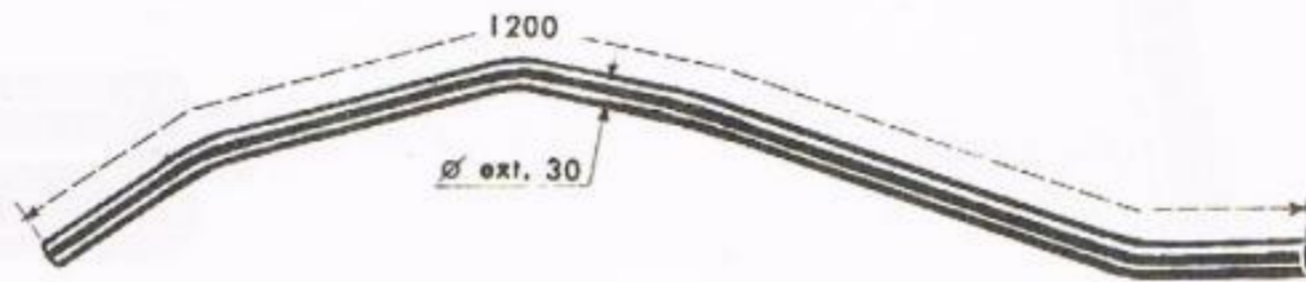

RENAULT N° 401

Tube AV

- 11 CV, KZ-11,12

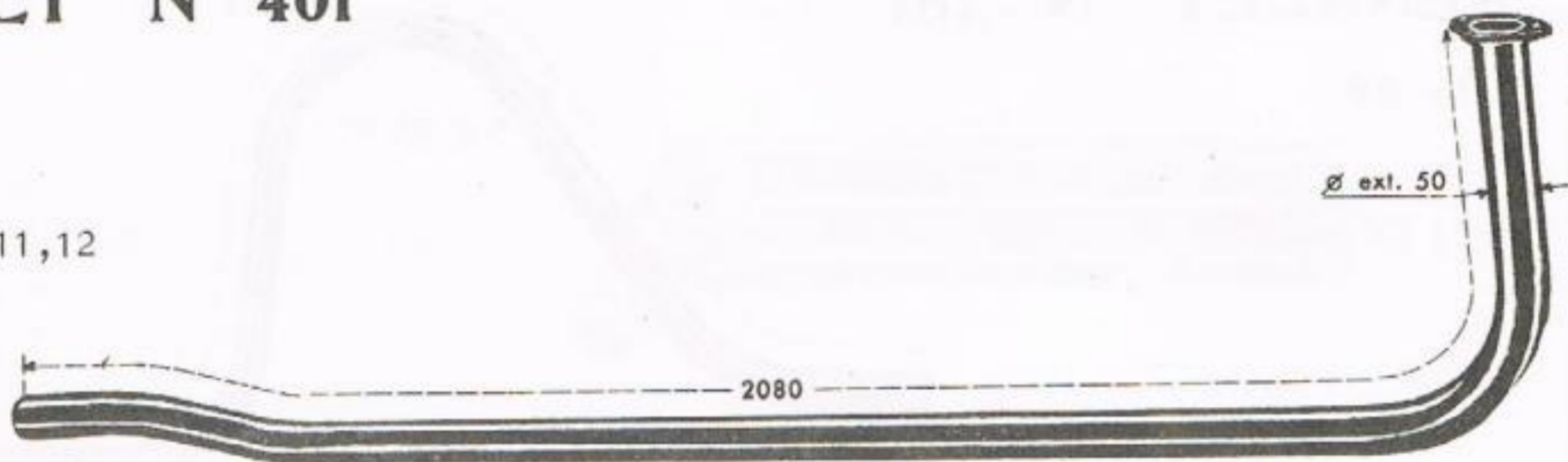

RENAULT N° 991

- 11 CV, KZ-11,12

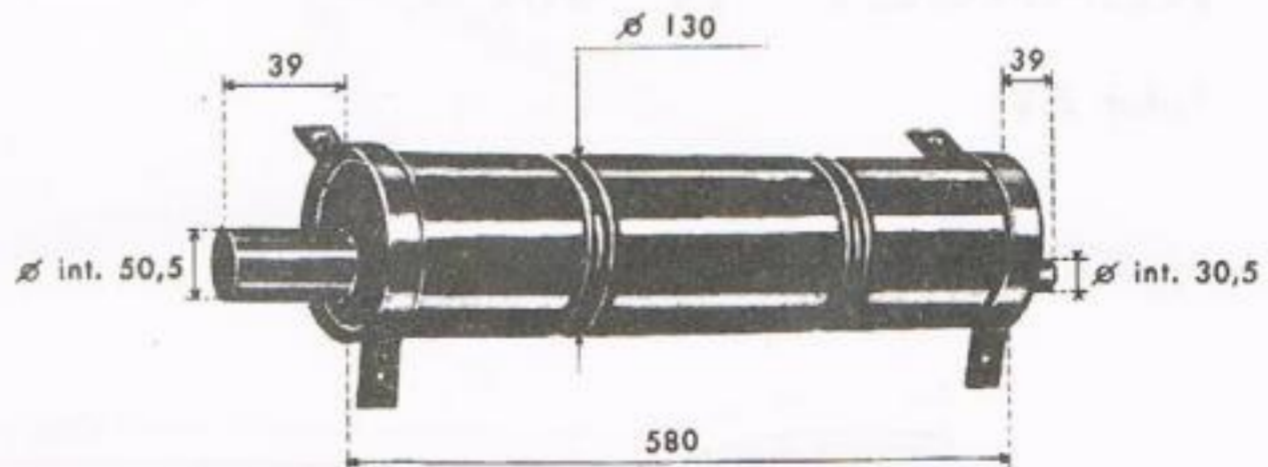

(Voir page 163, tube AR N° 281)

SILENCIEUX HG

Adaptables à

RENAULT N° 281

Tube AR

- 11 CV, KZ-11,12

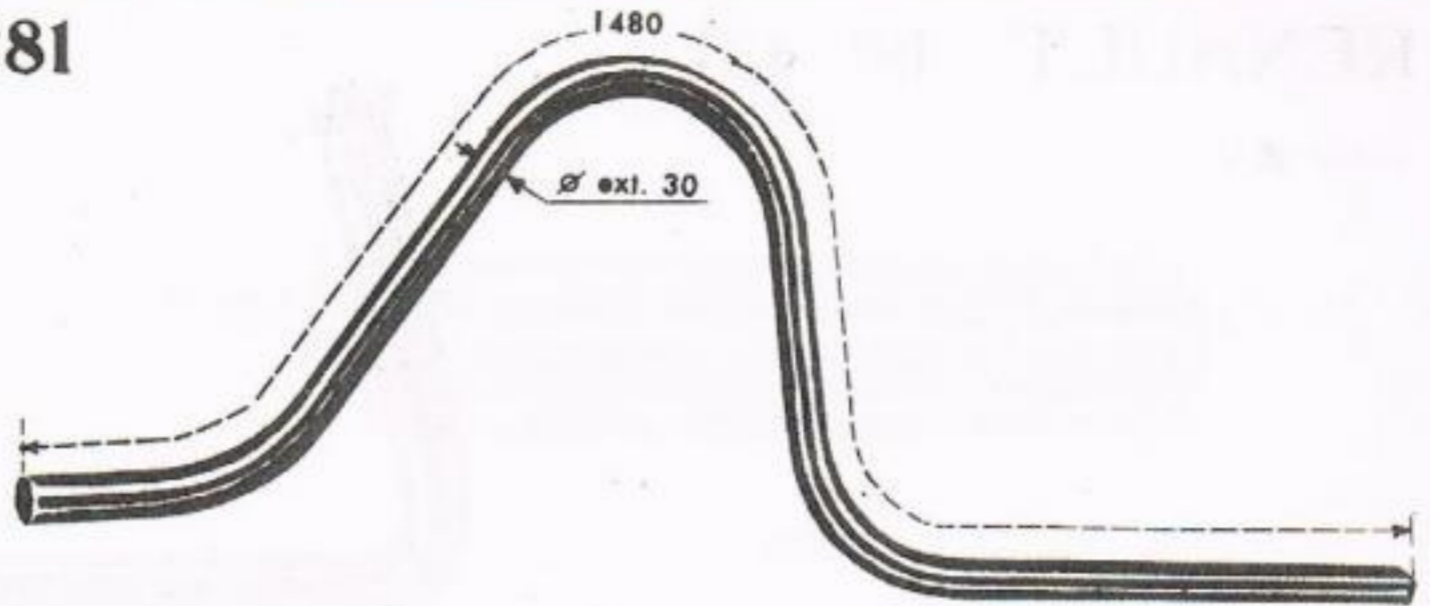

RENAULT N° 411

Tube AV

- 11 CV, KZ-13, KZ-17
(S'adapte sur KZ-13 en
ressoudant la bride 2
trous du vieux tube à
la place de la colle-
rette évasée)

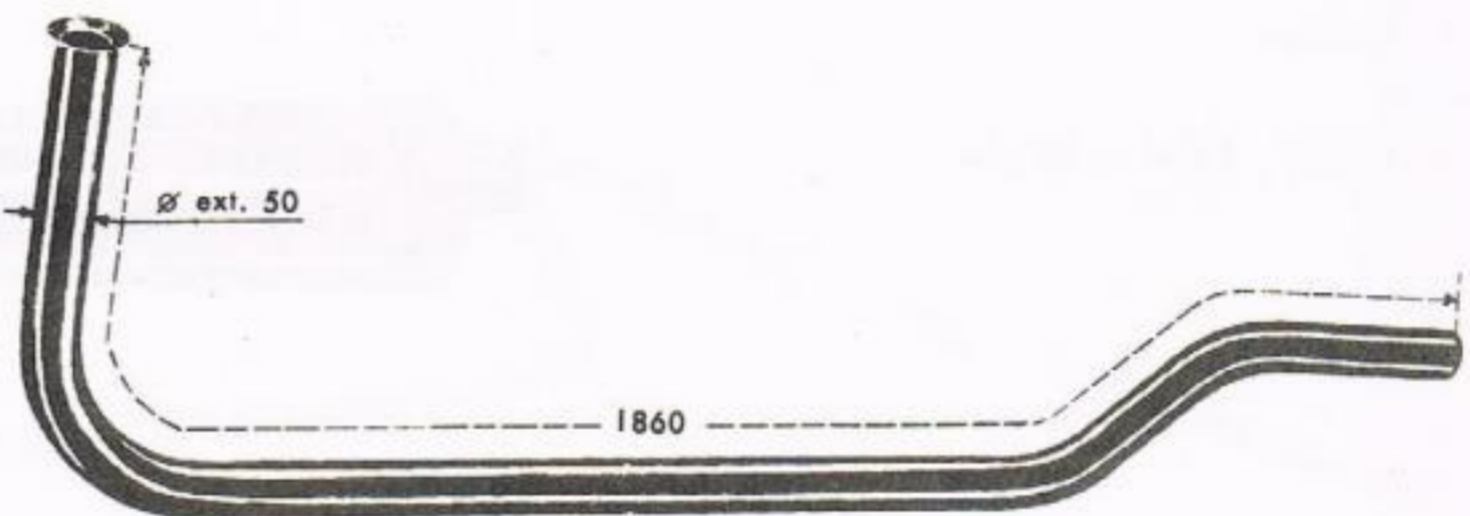

RENAULT N° 39

- 11 CV, KZ-13, KZ-17

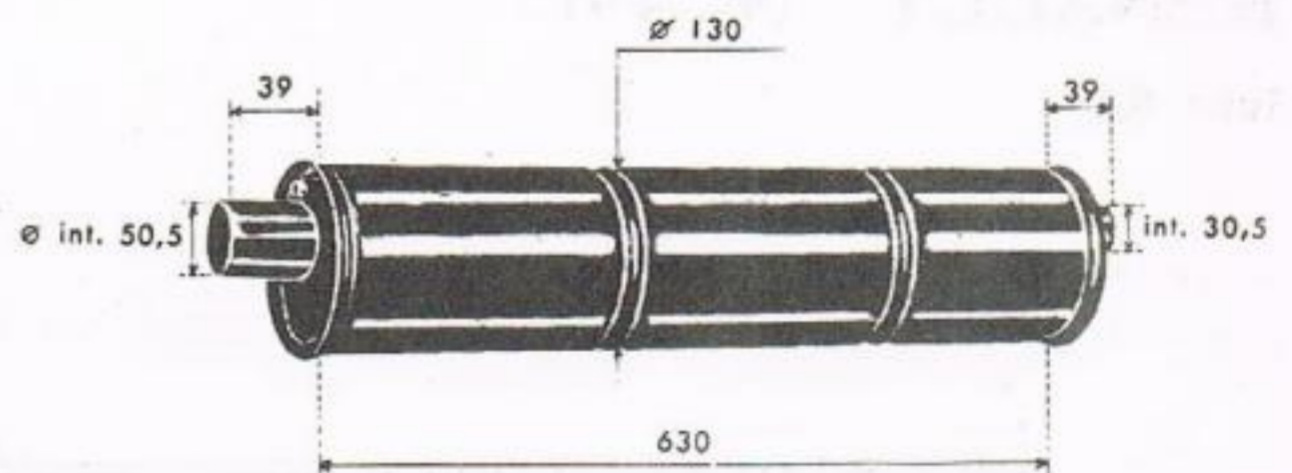

RENAULT N° 191

Tube AR

- 11 CV, KZ-13, KZ-17

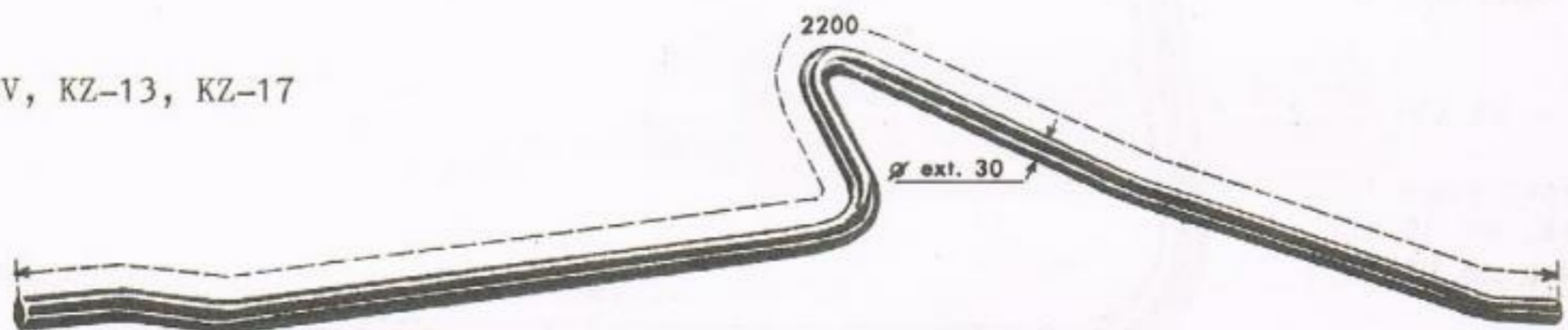

SILENCIEUX HG

Adaptables à

RENAULT N° 431

Tube AV

- 11 CV, KZ-14,18,24

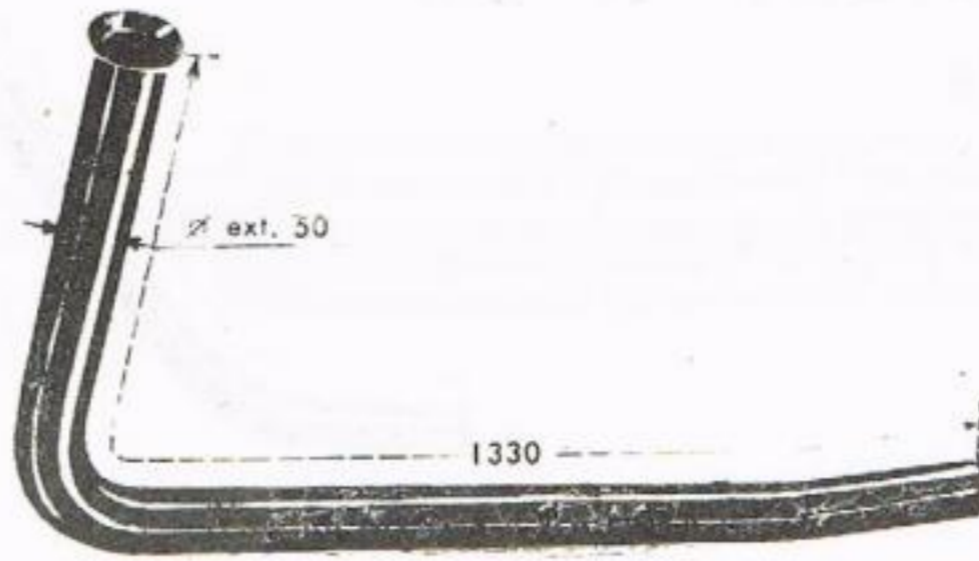

RENAULT N° 39

- 11 CV, KZ-14,18,24

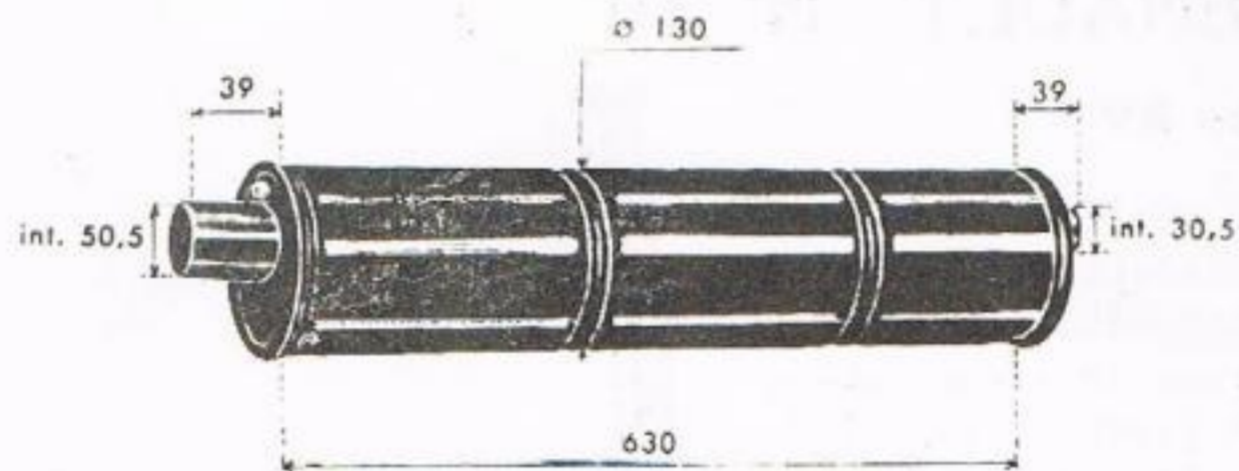

RENAULT N° 491

Tube AR

- 11 CV, KZ-14,18,24

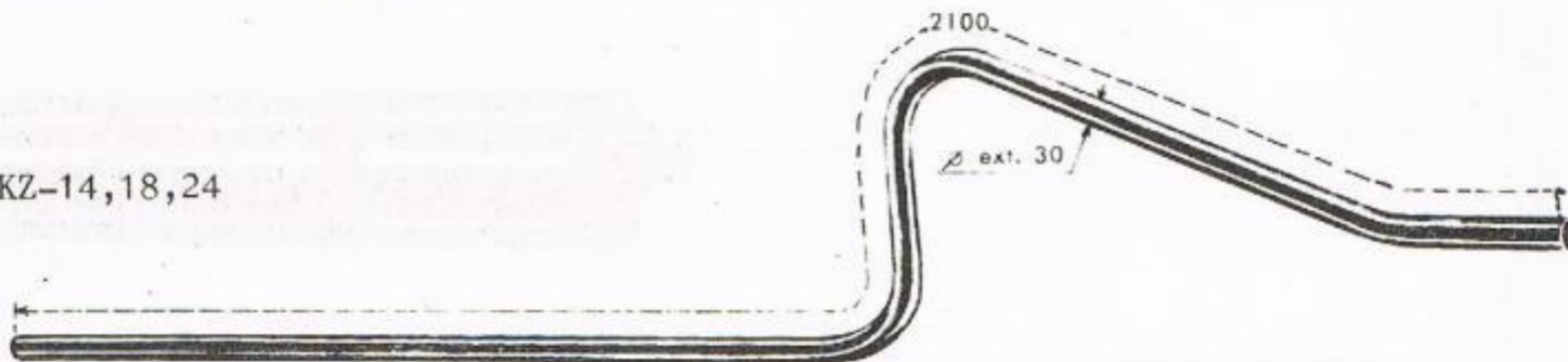

RENAULT N° 421

Tube AV

- 11 CV, KZ-23

(Voir page 165,
sil. N° 39 et
tube AR N° 191)

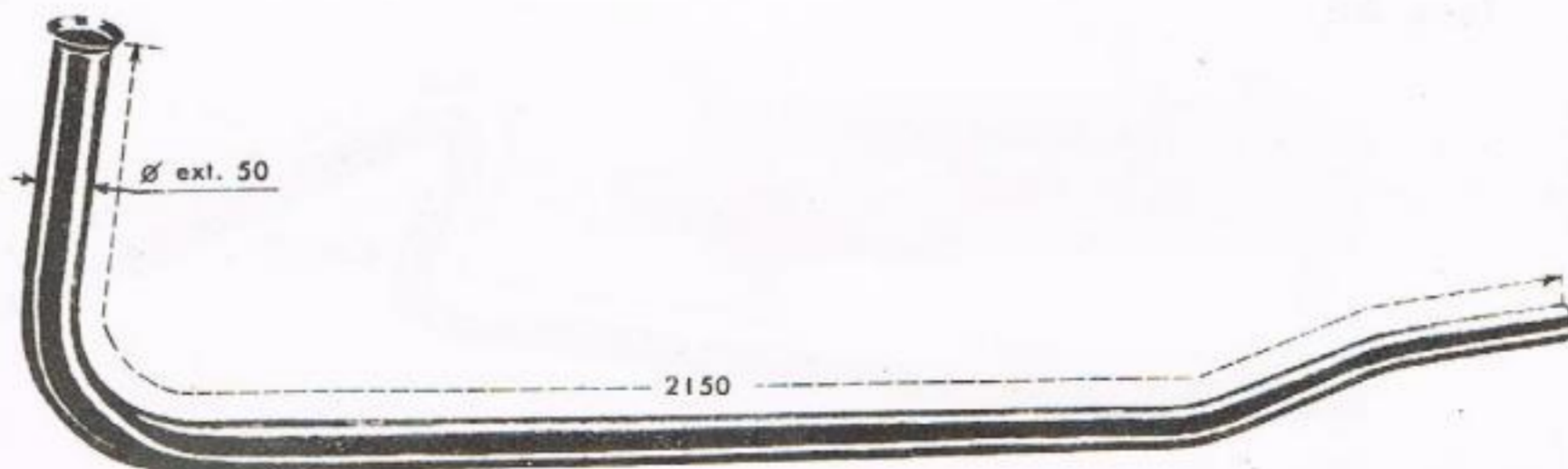

SILENCIEUX HG

Adaptables à

RENAULT N° 39

- 11 CV, KZ-23

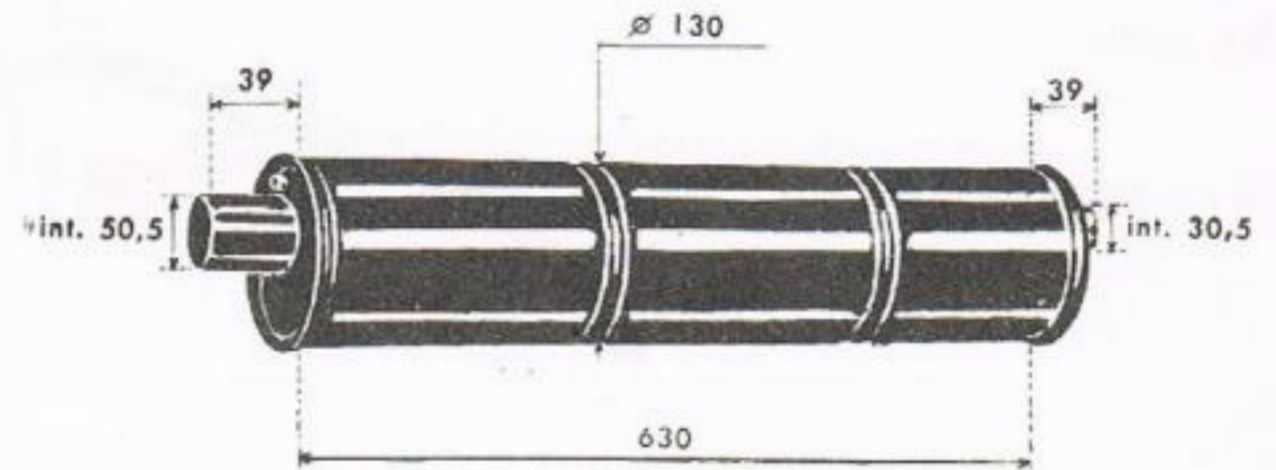

RENAULT N° 191

Tube AR

- 11 CV, KZ-23

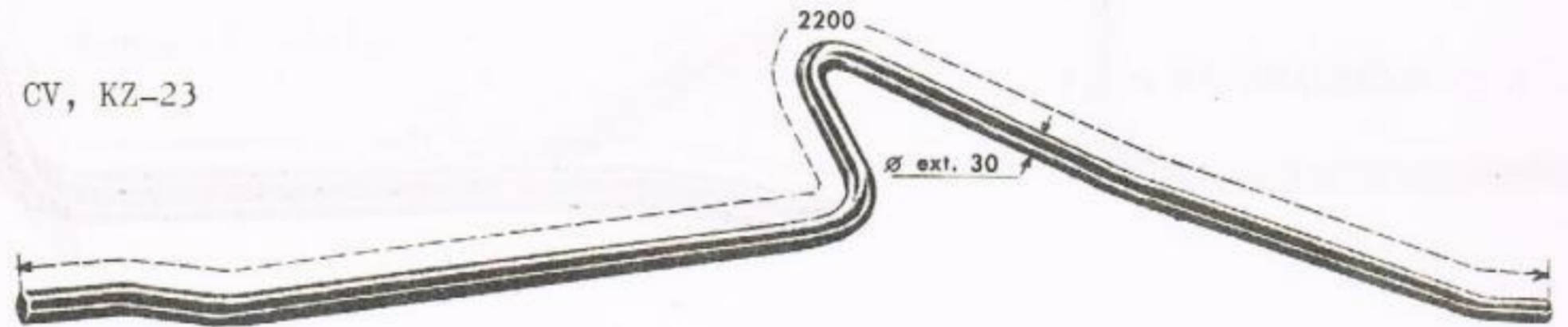

RENAULT N° 53

- 8 CV MONAQUATRE-UY

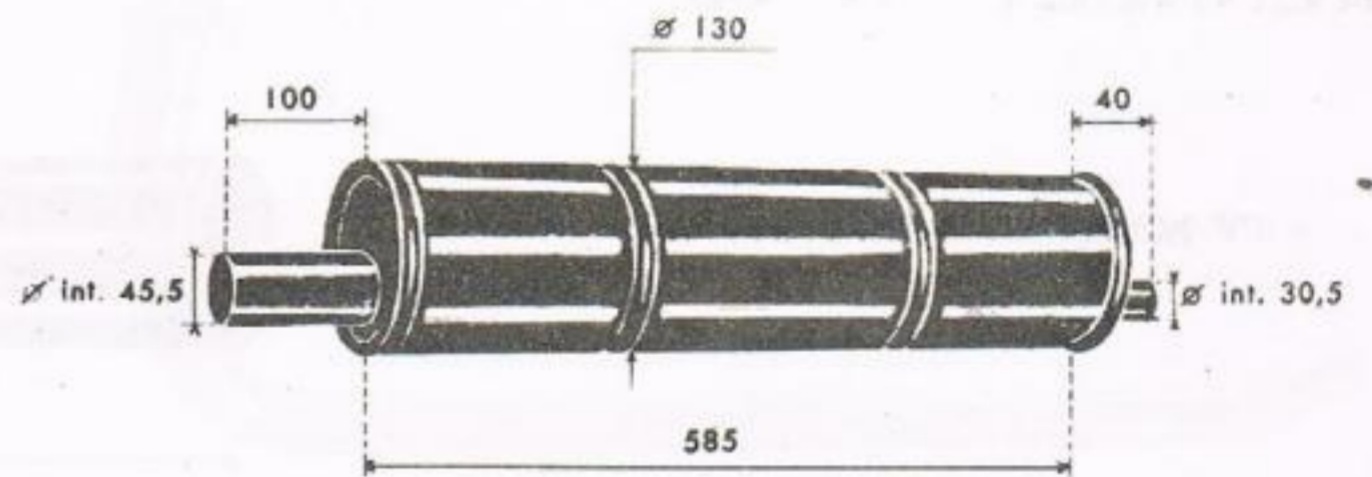

RENAULT N° 53

- 8 CV MONAQUATRE-YN-1

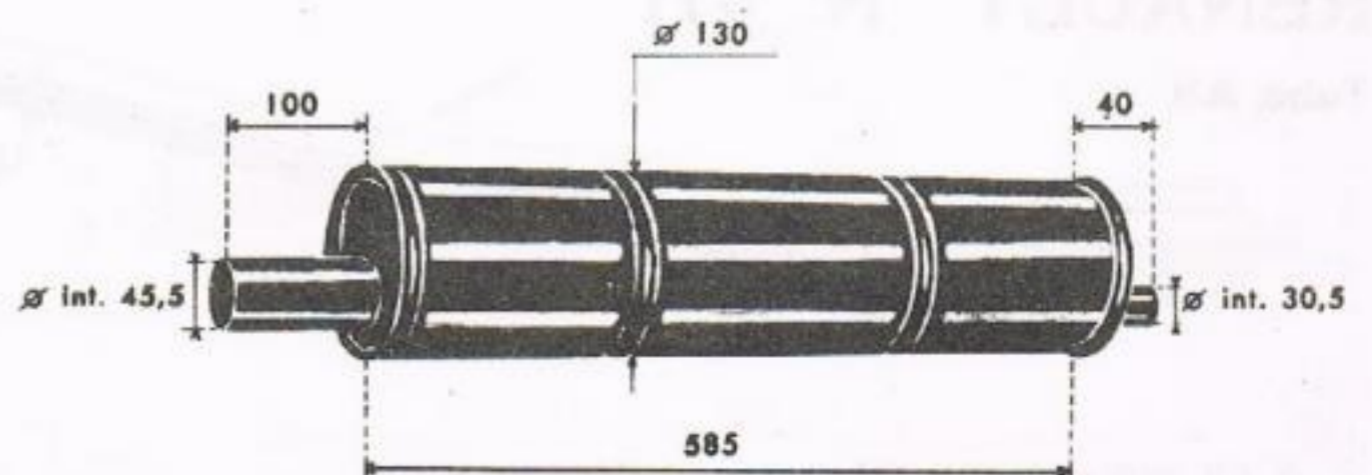

(Voir page 166, tube AR N° 621)

SILENCIEUX HG

Adaptables à

RENAULT N° 621

Tube sortie

- 8 CV MONAQUATRE-YN-1

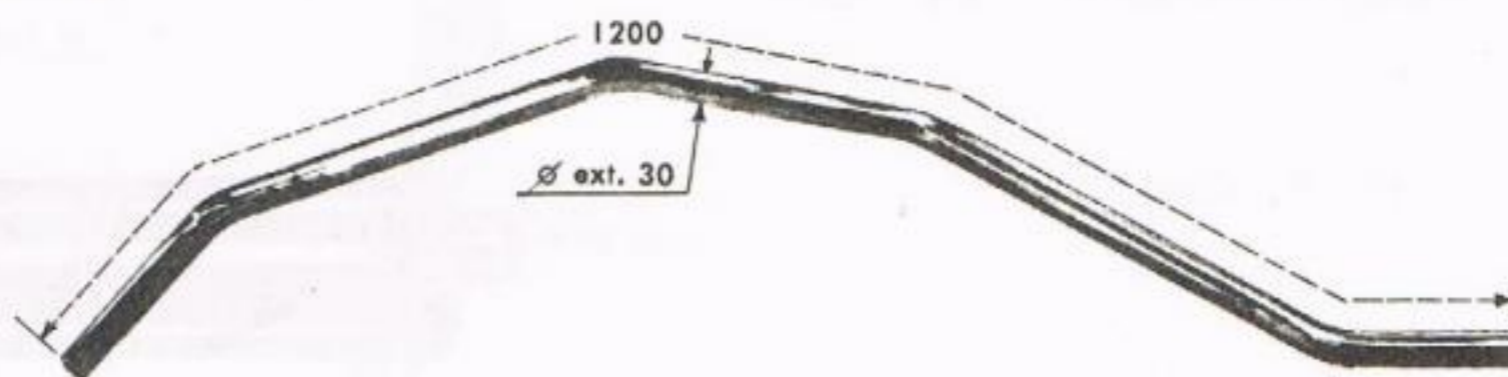

RENAULT N° 311

Tube AV

- 8 CV MONAQUATRE-YN-2,3,4

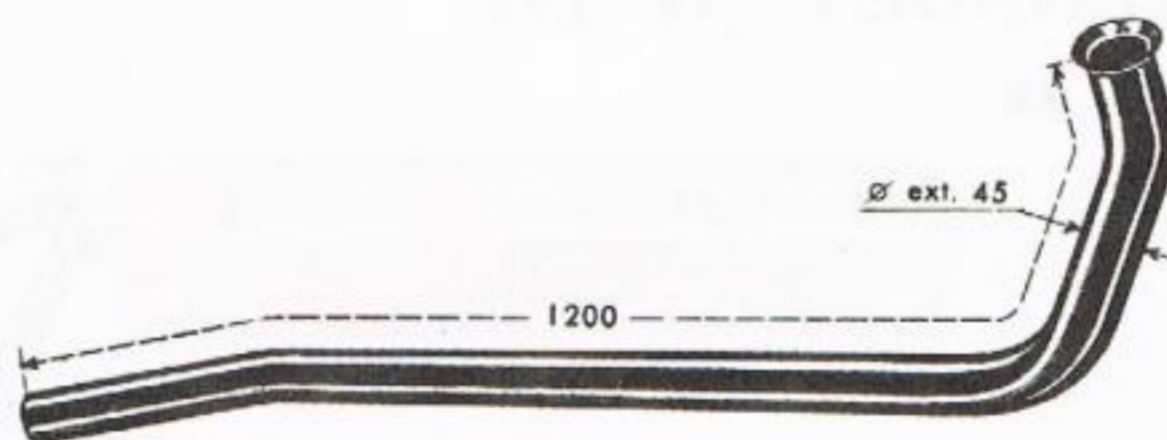

RENAULT N° 53

- 8 CV MONAQUATRE-YN-2,3,4

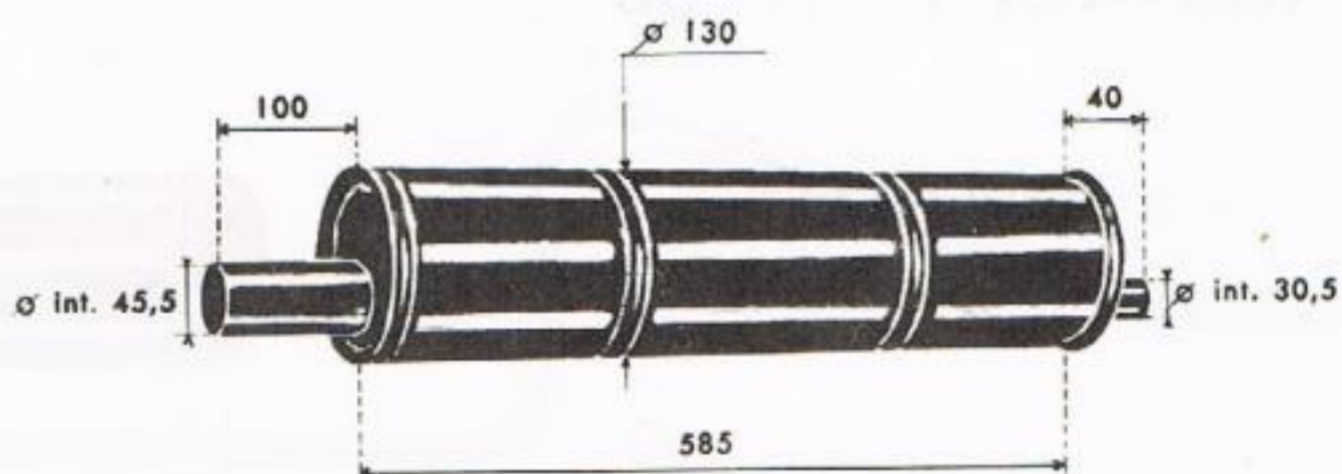

RENAULT N° 471

Tube AR

- 8 CV MONAQUATRE-YN-2,3,4

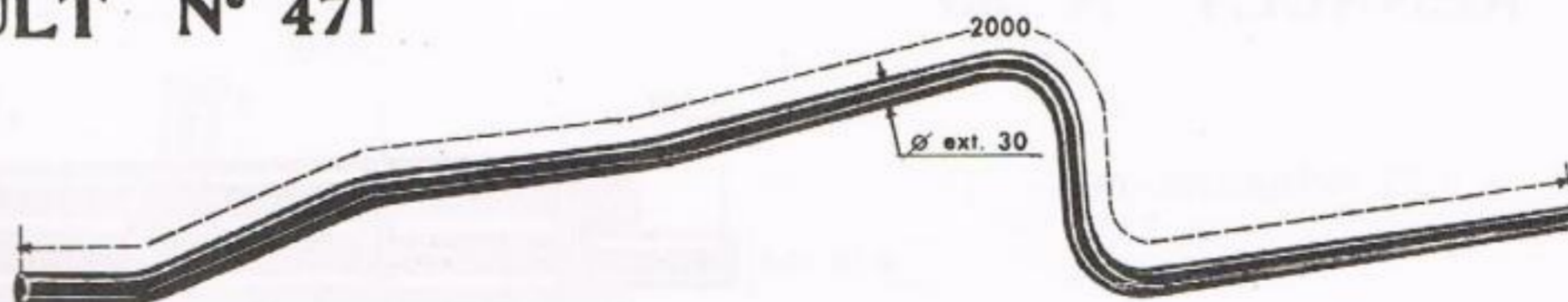

SILENCIEUX HG

Adaptables à

RENAULT N° 63

- 8 CV CELTAQUATRE
ZR-1,2

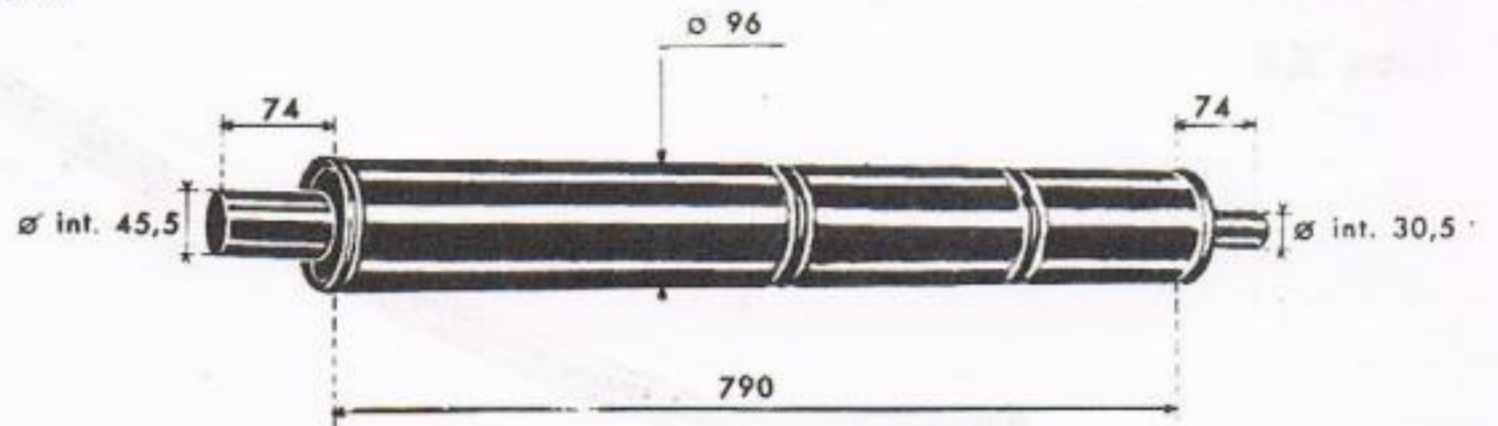

RENAULT N° 501

Tube AR

- 8 CV CELTAQUATRE ZR-1,2

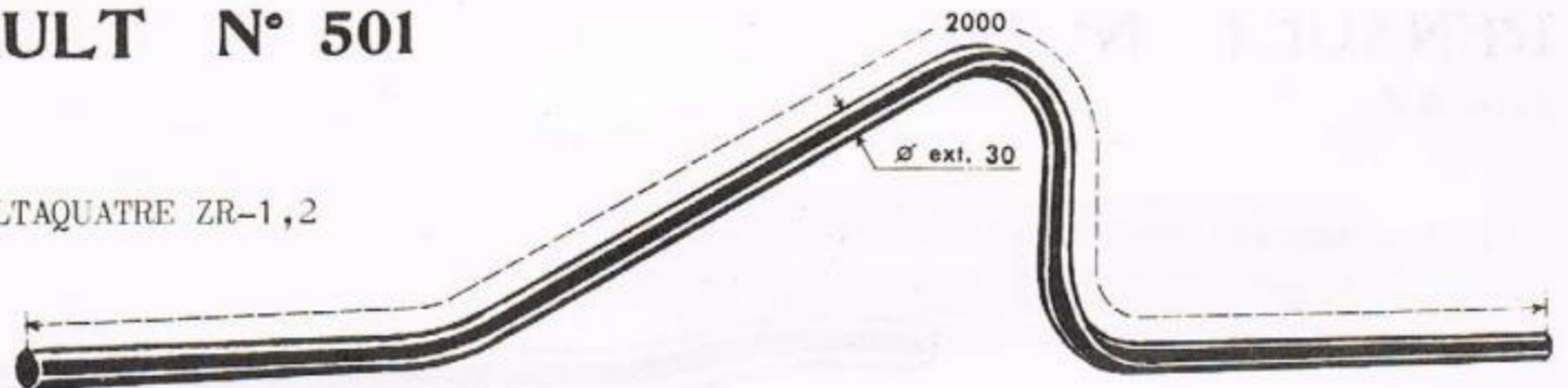

RENAULT N° 231

Tube AV

- 8 CV CELTAQUATRE ADC-1,2,3
BCR-1,2



RENAULT N° 32

- 8 CV CELTAQUATRE ADC-1,2,3
BCR-1,2

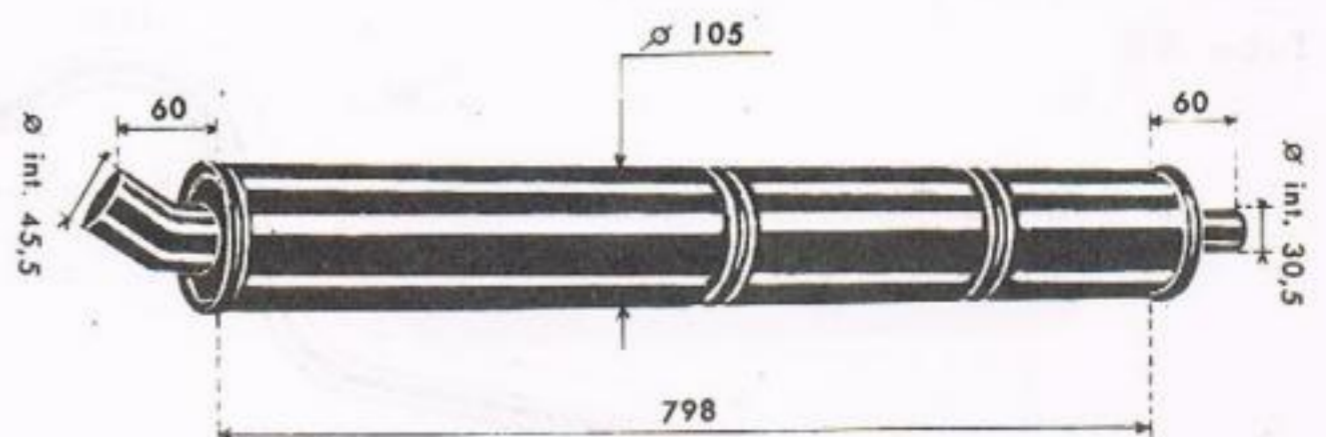

(Voir page N° 168, tube AR N° 161)

SILENCIEUX HG

Adaptables à

RENAULT N° 161

Tube AR

- 8 CV CELTAQUATRE ADC-1,2,3
- BCR-1,2

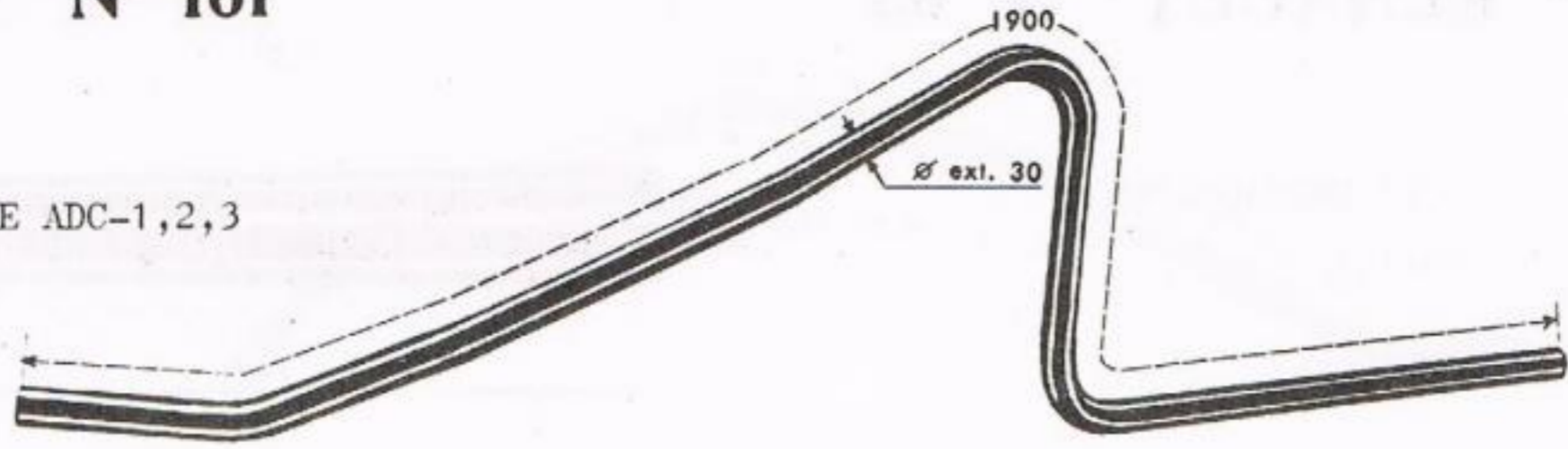

RENAULT N° 221

Tube AV

- 14 CV - ACL-1,2

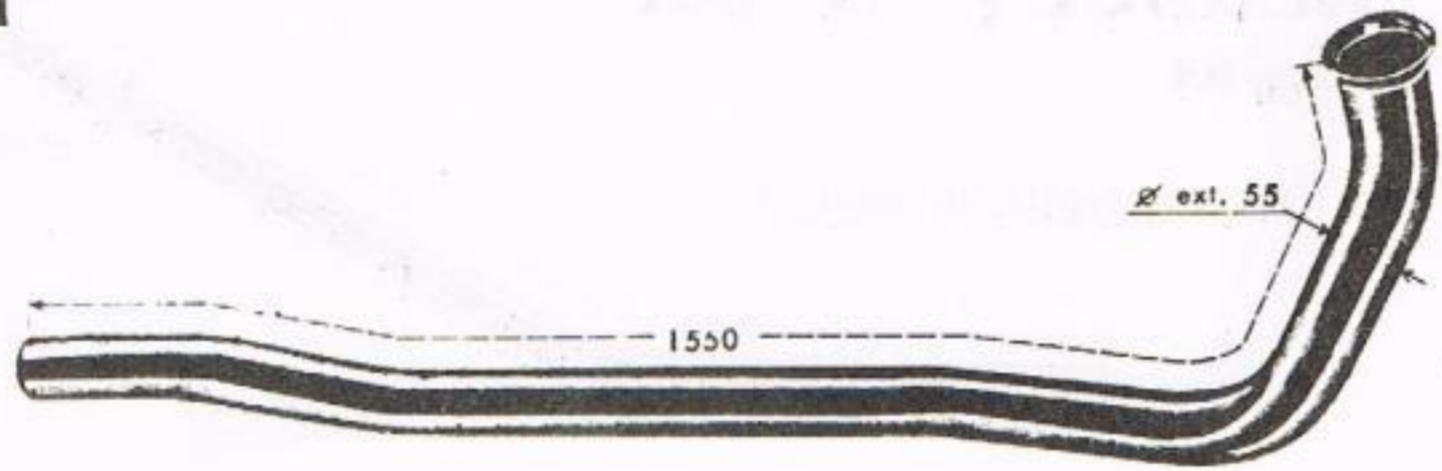

RENAULT N° 88

- 14 CV - ACL-1,2

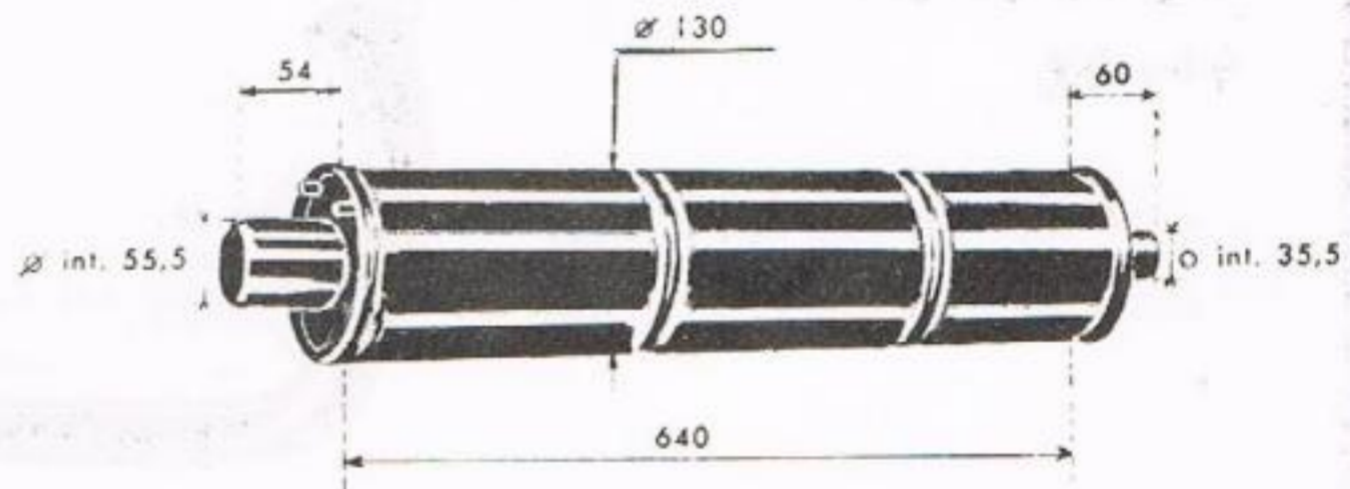

RENAULT N° 211

Tube AR

- 14 CV - ACL-1,2

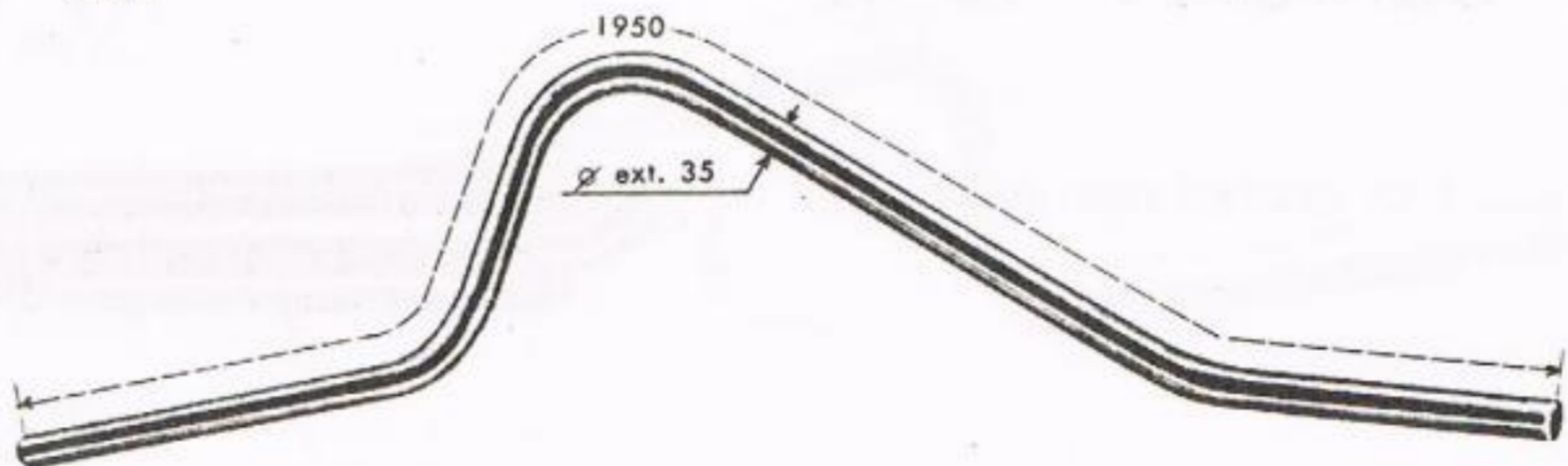

SILENCIEUX HG

Adaptables à

RENAULT N° 56

- 14 CV, ADG-1

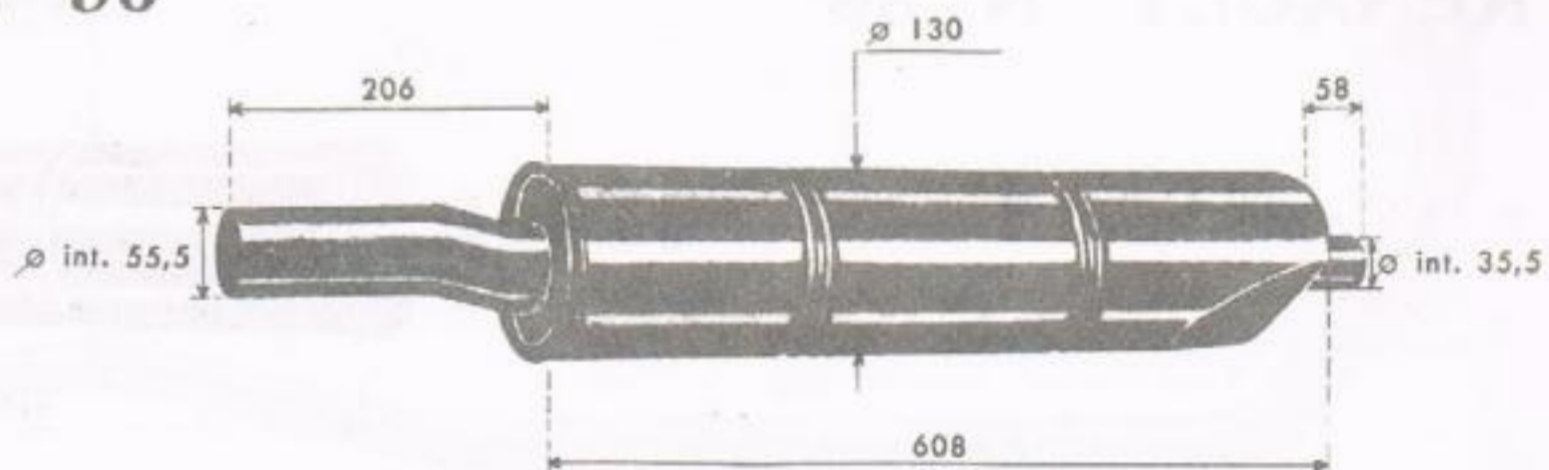

RENAULT N° 88

- 14 CV, ADL-1, BDH-1

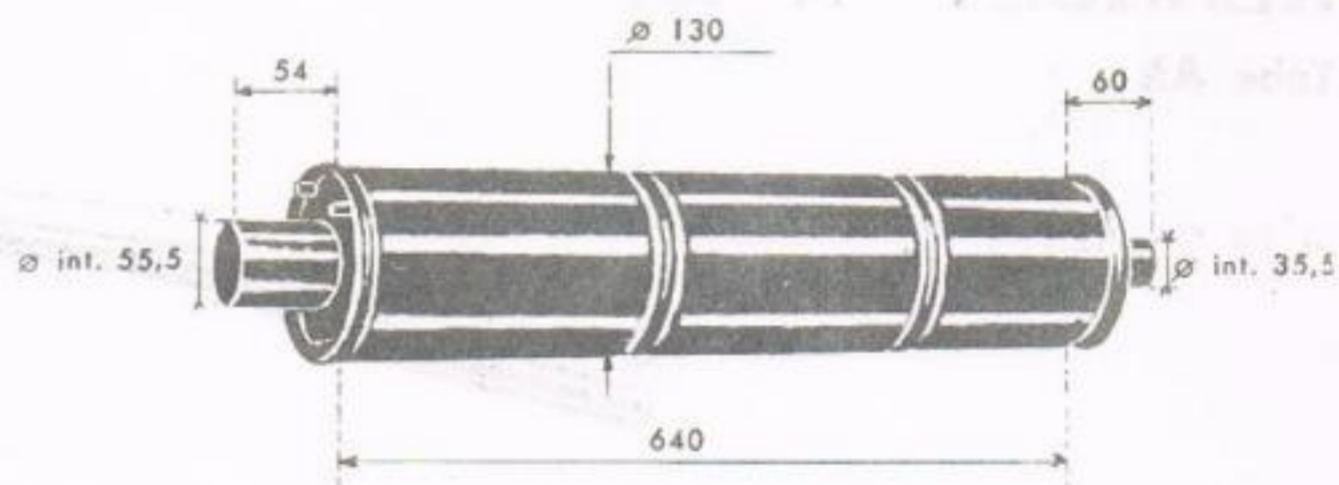

RENAULT N° 301

Tube AV

- 14 CV, ADL-2



RENAULT N° 37

- 14 CV, ADL-2

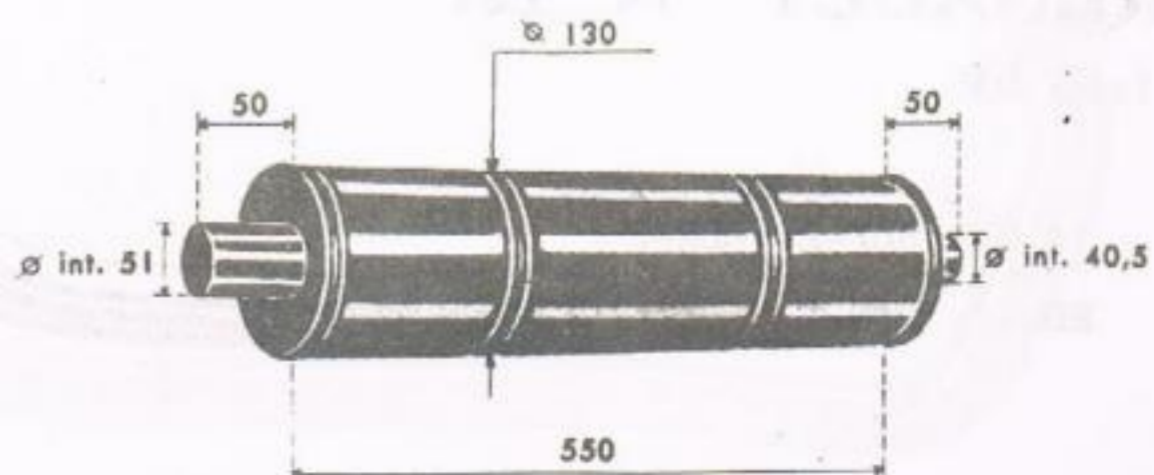

SILENCIEUX HG

Adaptables à

RENAULT N° 88

- 14 CV, BDF-1

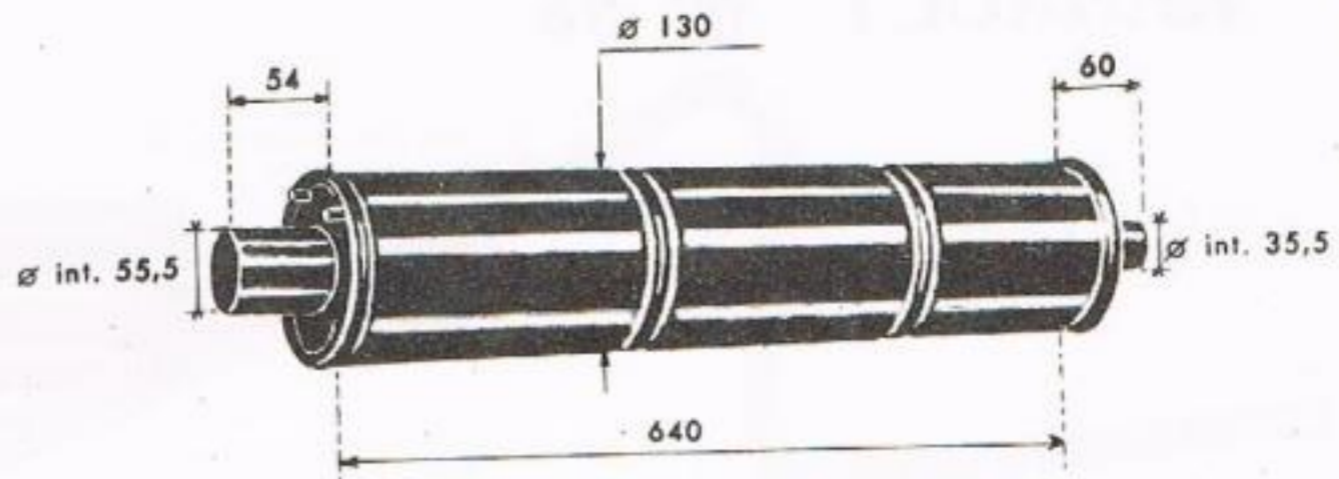

RENAULT N° 151

Tube AR

- 14 CV, BDF-1



RENAULT N° 34

- 14 CV, BDF-2, BDR-2, BDS-2, BFG-1

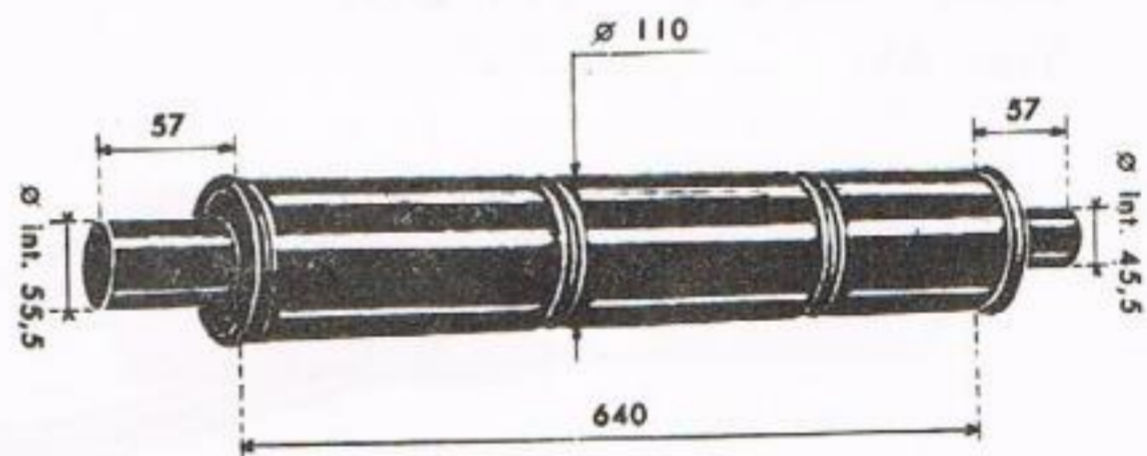

RENAULT N° 121

Tube AR

- 14 CV, BDF-2, BDR-2
BDS-2, BFG-1

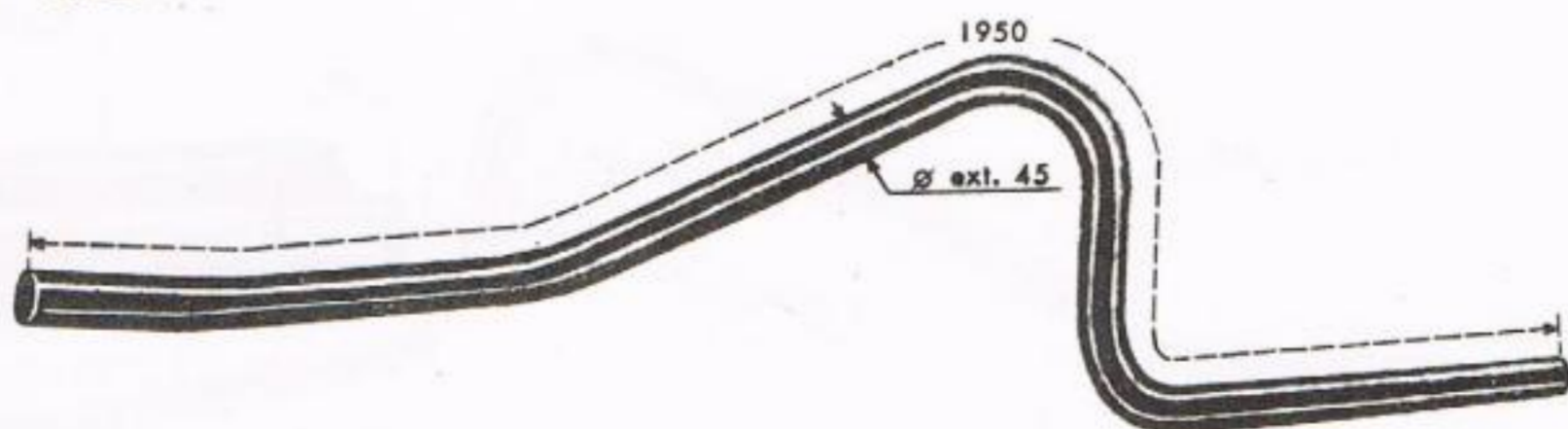

SILENCIEUX HG

Adaptables à

RENAULT N° 301

Tube AV

- 14 CV, BDH-2 à 5

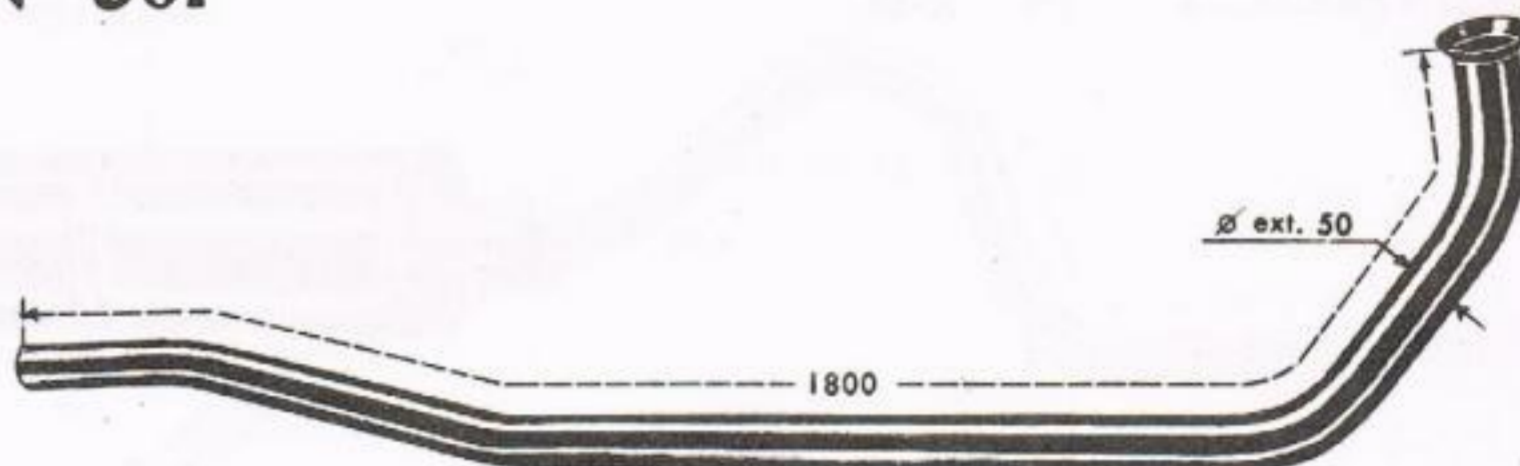

RENAULT N° 37

- 14 CV, BDH-2 à 5

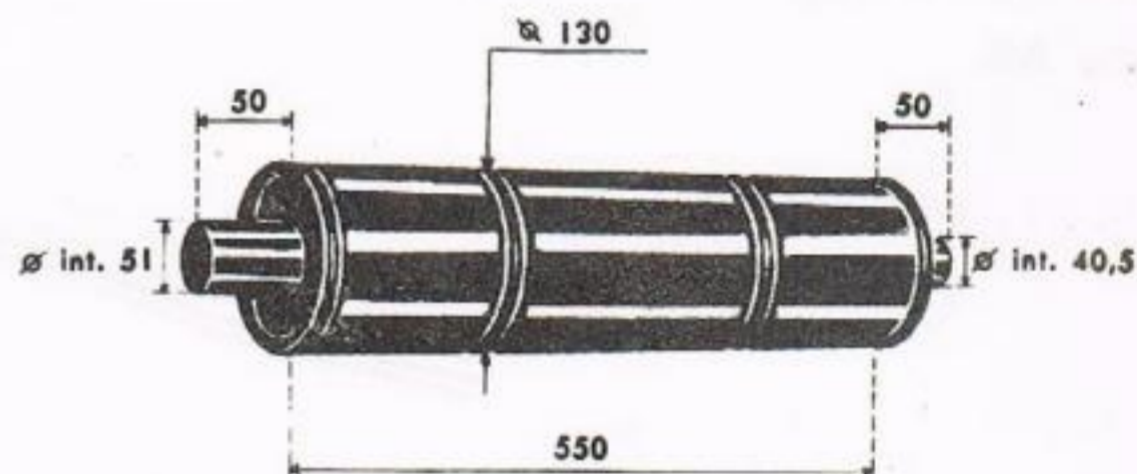

RENAULT N° 321

Tube AR

- 14 CV, BDH-2 à 5

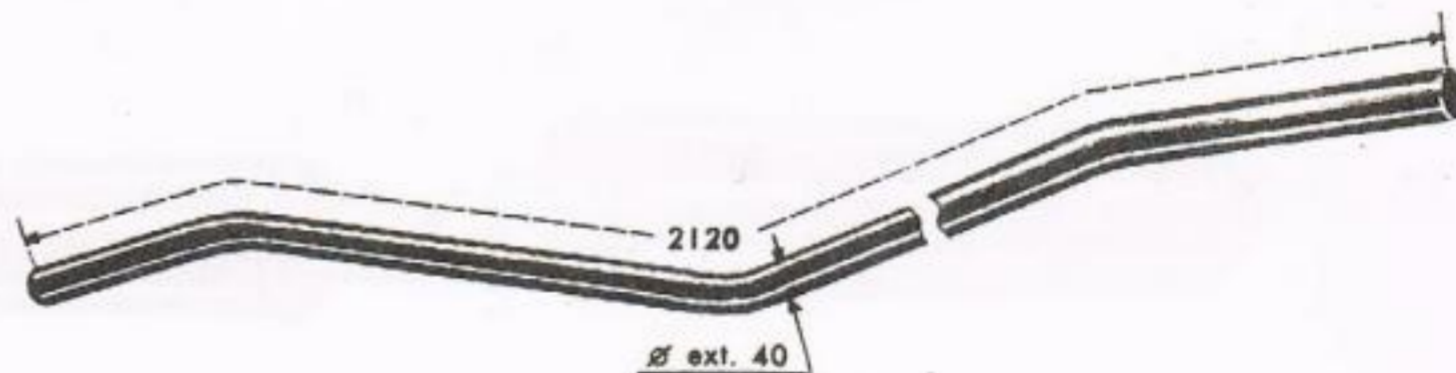

RENAULT N° 221

Tube AV

- 14 CV, BDJ-1

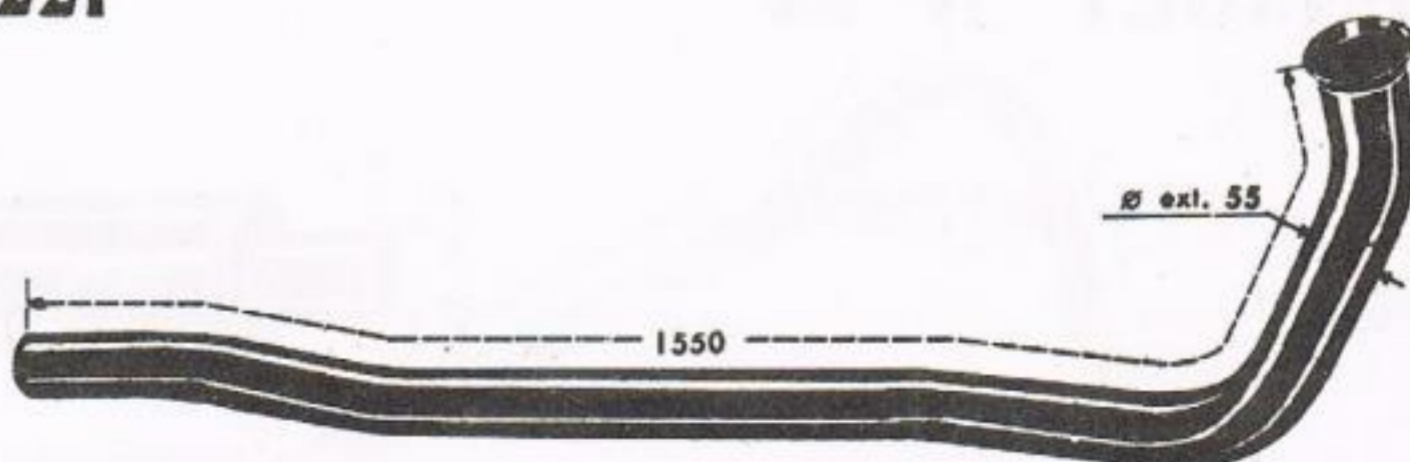

(Voir page 172, sil. N° 88 et tube AR N° 151)

SILENCIEUX HG

Adaptables à

RENAULT N° 88

- 14 CV, BDJ-1

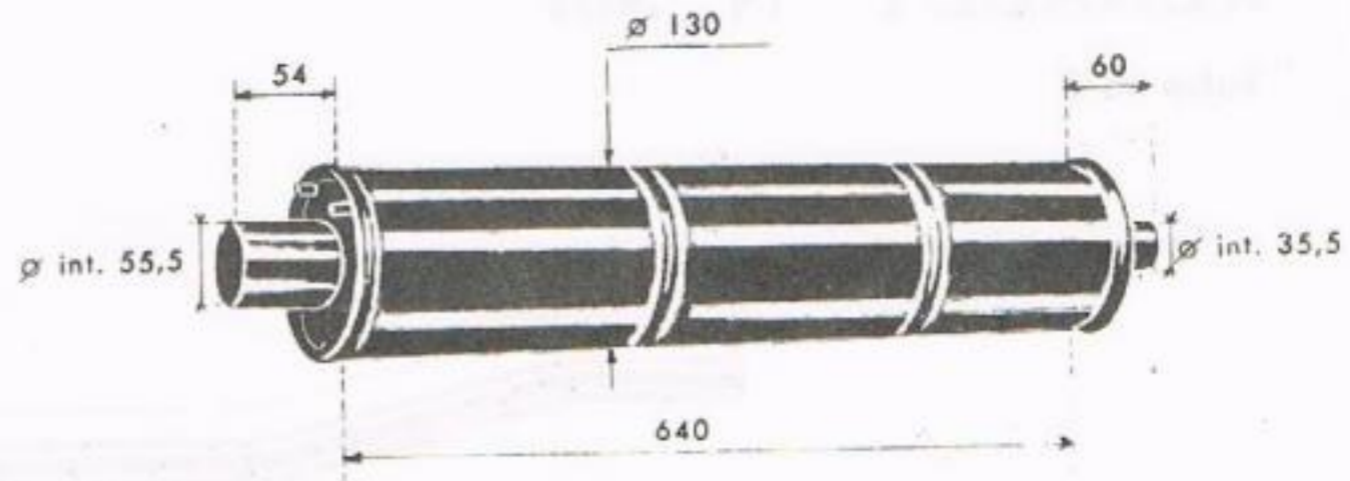

RENAULT N° 151

Tube AR

- 14 CV, BDJ-1



RENAULT N° 34

- 14 CV, BDJ-2

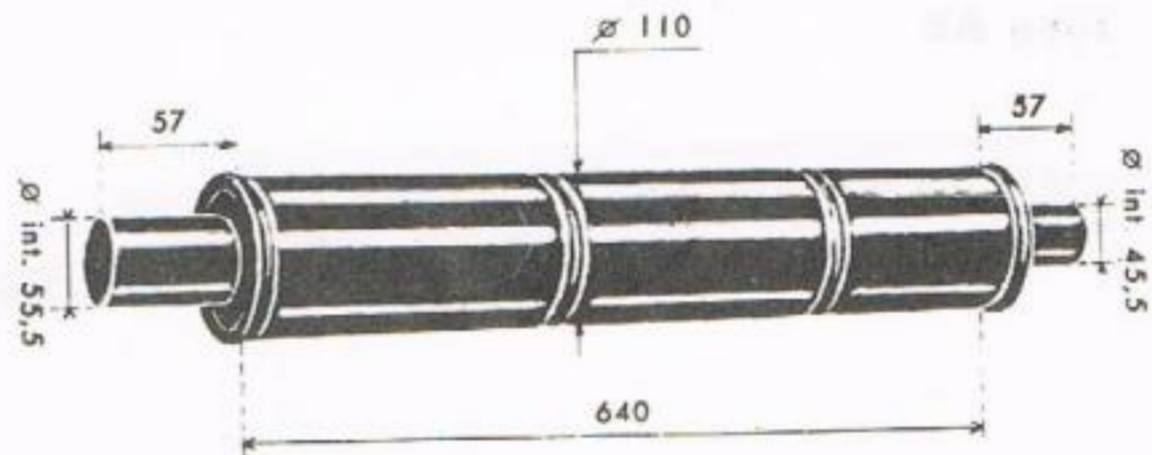

RENAULT N° 34

- 14 CV, BDR-1, BDS-1, BDT-1

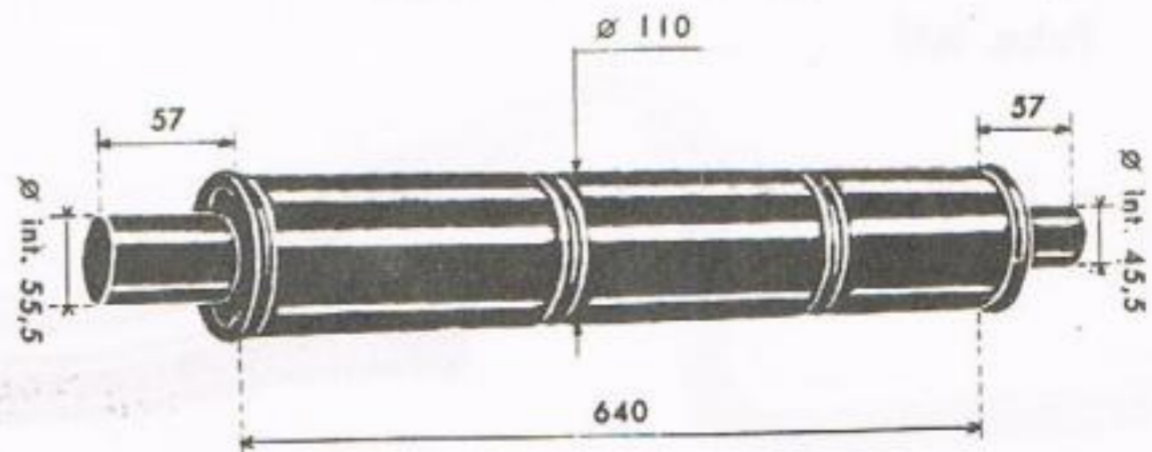

(Voir page N° 173, tube AR N° 131)

SILENCIEUX HG

Adaptables à

RENAULT N° 131

Tube AR

- 14 CV, BDR-1, BDS-1, BDT-1

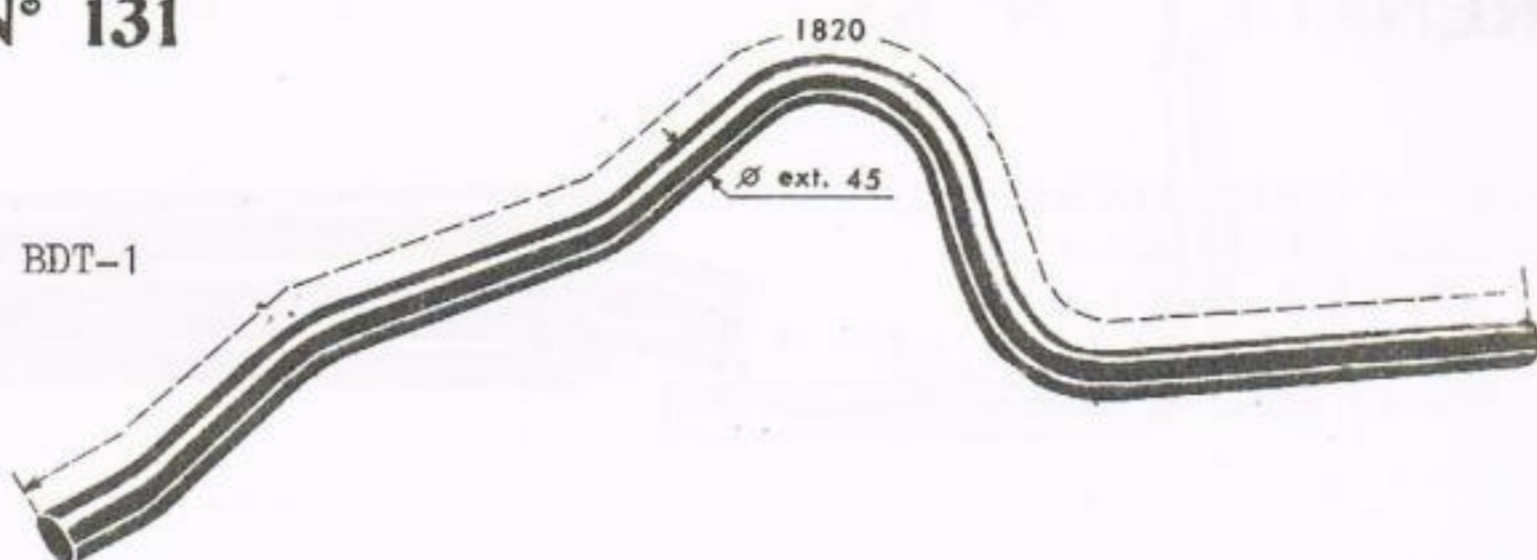

RENAULT N° 37

- 14 CV, BDR-3, BFH-1

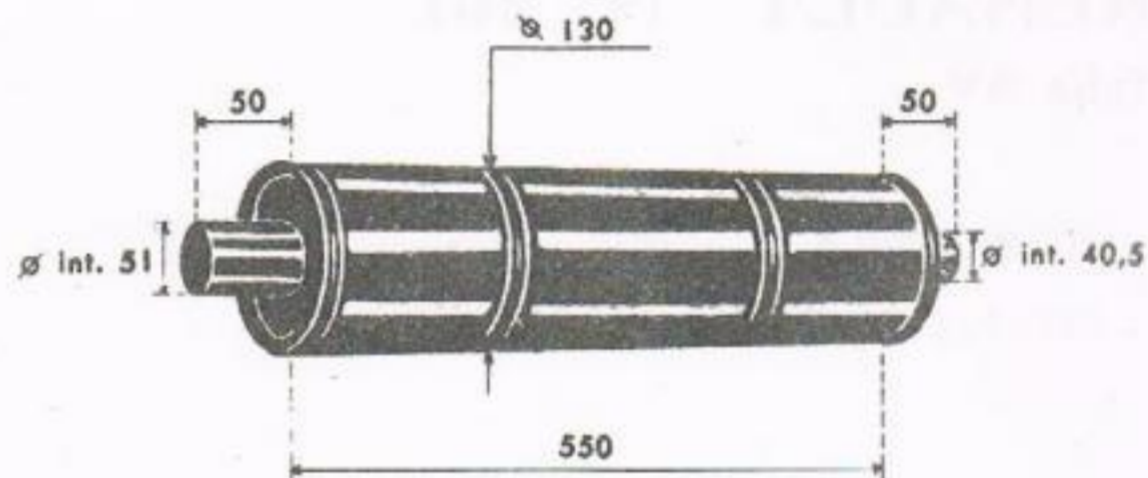

RENAULT N° 37

- 14 CV, BDS-3, BFG-2,3, BFP-1,2

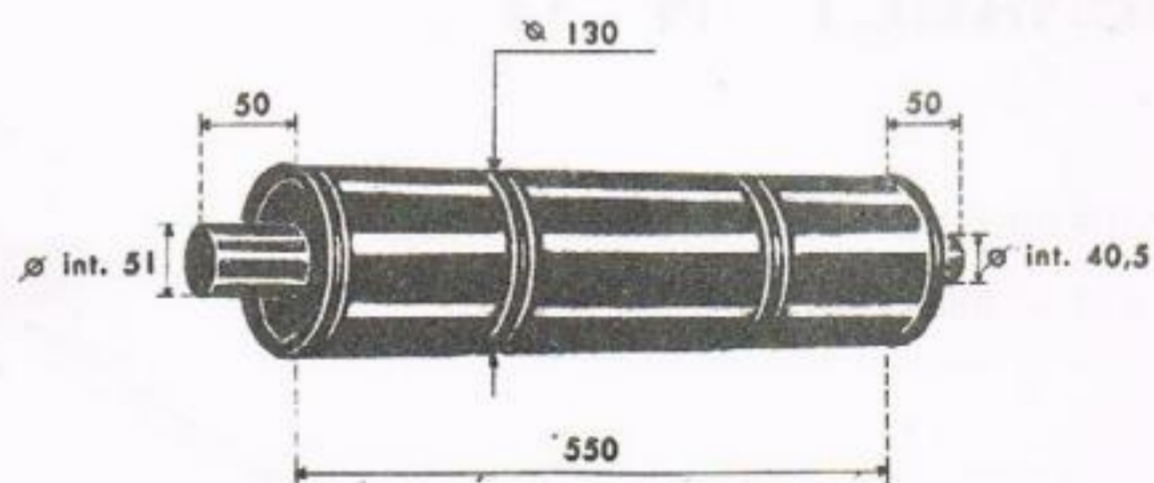

RENAULT N° 141

Tube AR

- 14 CV, BDS-3, BFG-2,3, BFP-1,2

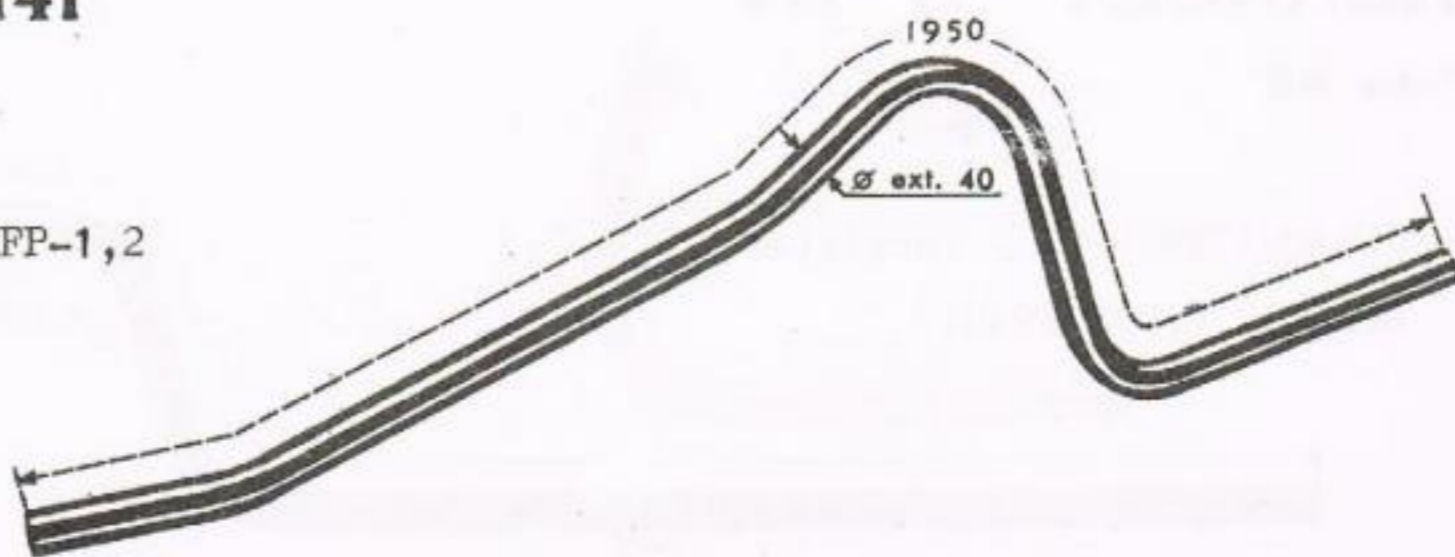

SILENCIEUX HG

Adaptables à

RENAULT N° 54

- 23 CV VIVASTELLA et VIVA GRAND SPORT, ACR-1,2, ACX-1 à 3, ADB-1 à 3, BCT-1, BCX-1,2, BCY-1, BDV-1, BDZ-1

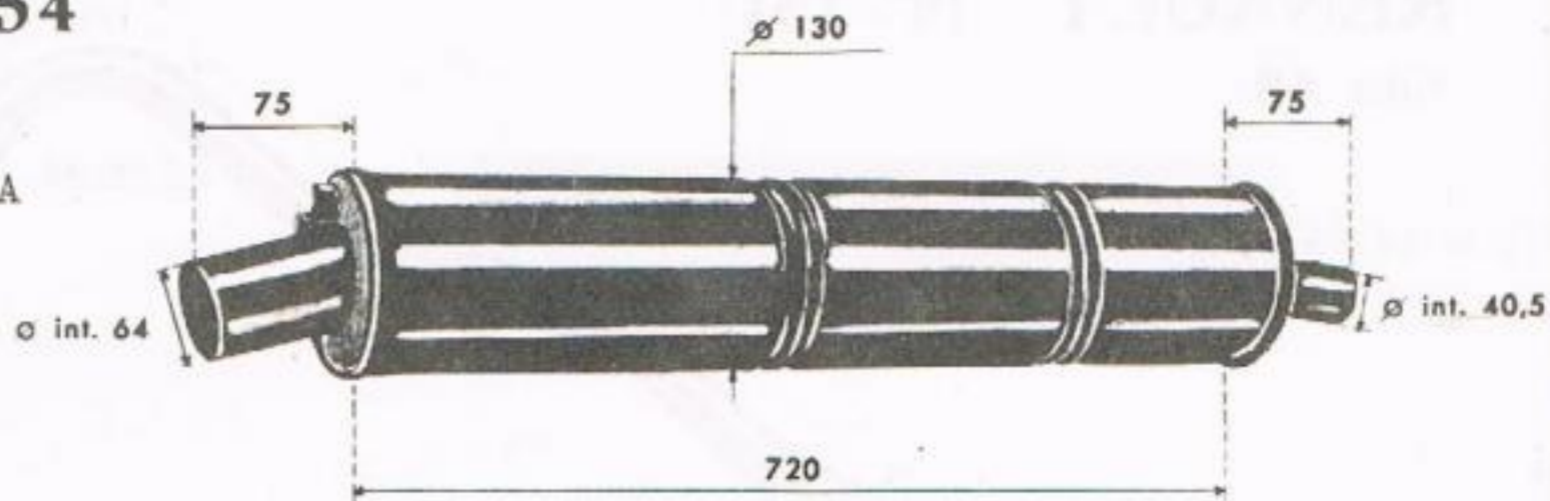

RENAULT N° 201

Tube AV

- JUVAQUATRE 6 CV - Touristes AEB-1,2,3 BFK-1,2 (1938/1940)

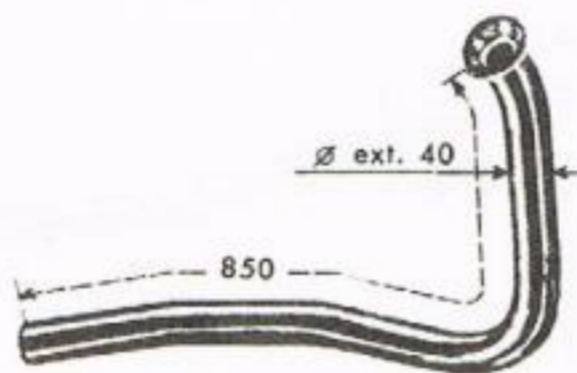

RENAULT N° 33

- JUVAQUATRE 6 CV - Touristes AEB-1, 2,3 - BFK-1,2 (1938/1940)

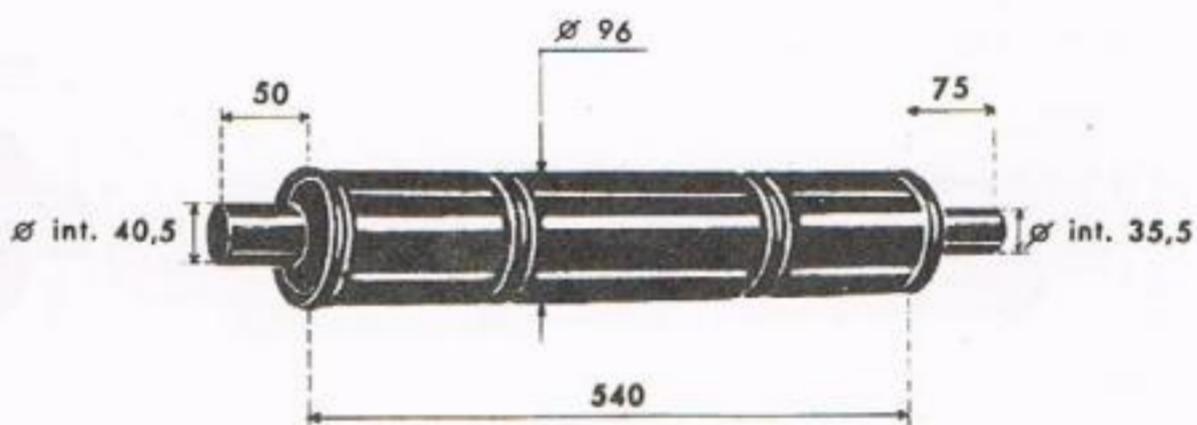

RENAULT N° 171

Tube AR

- JUVAQUATRE 6 CV - Touristes AEB-1,2,3 BFK-1,2 (1938/1940)

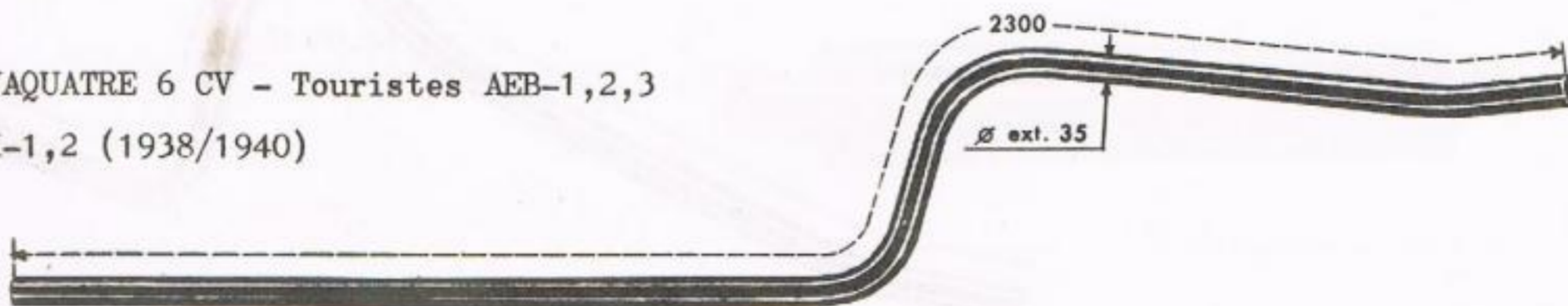

SILENCIEUX HG

Adaptables à

RENAULT N° 441

Tube AV

- Camionnettes 11 CV
OSB, OSC, PRB, PRC

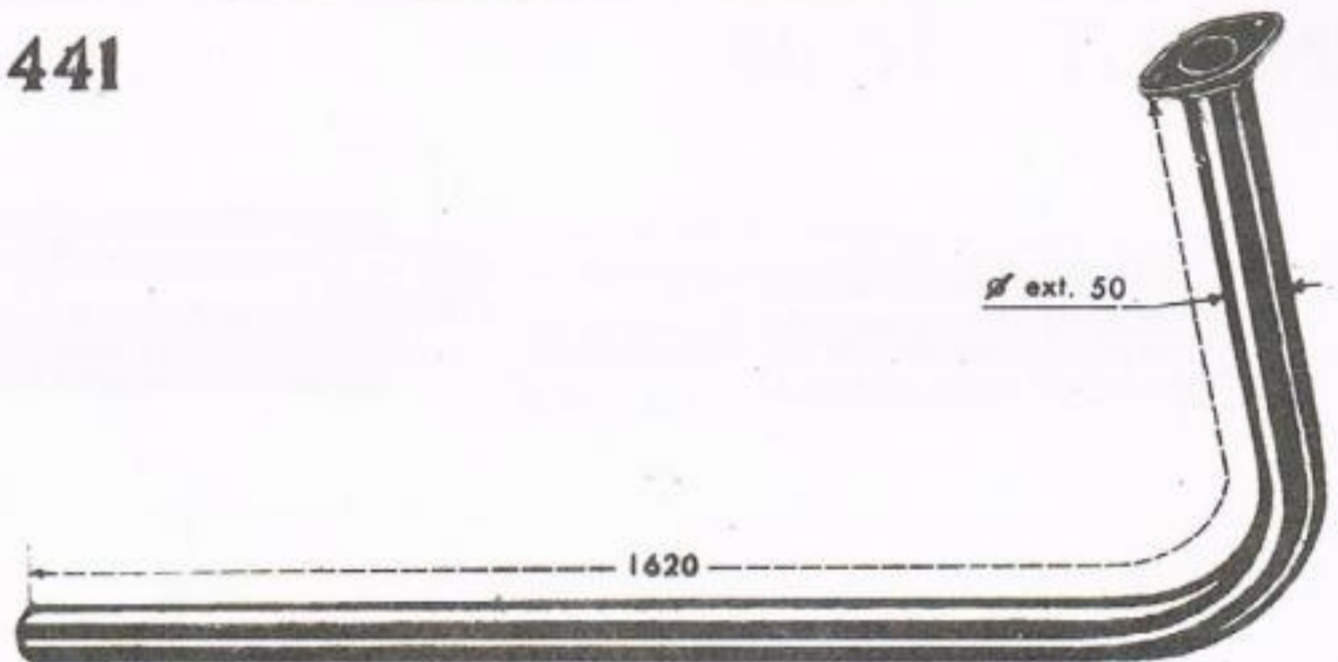

RENAULT N° 39

- Camionnettes 11 CV
OSB, OSC, PRB, PRC

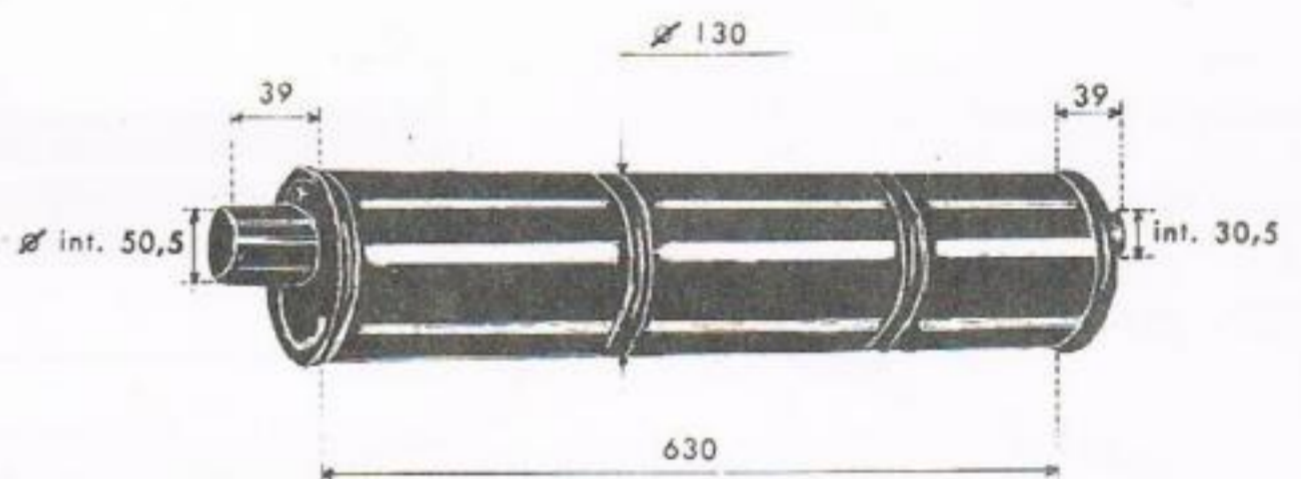

RENAULT N° 39

- Camionnettes 11 CV
KZB, KZC, KZE

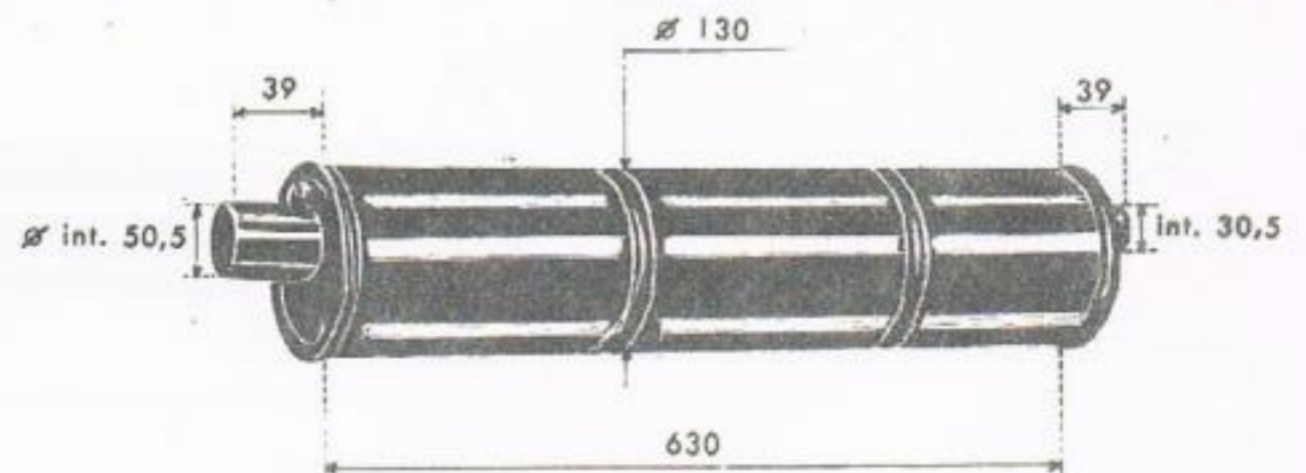

RENAULT N° 391

Tube AV

- Camionnettes 11 CV
ZJC



(Voir page 206, sil. N° 39)

SILENCIEUX HG

Adaptables à

RENAULT N° 39

- Camionnettes 11 CV, ZJC

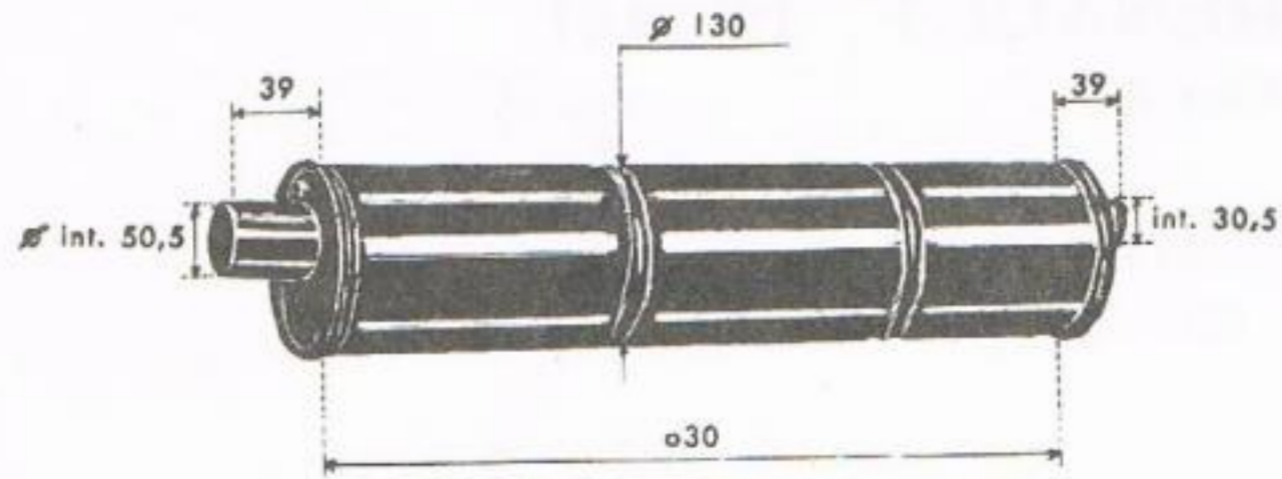

RENAULT N° 86

- Camions et Cars 12 CV et
15 CV - YFAB, YFAC, YFDB,
YEDC, YGAB, YGAC, YGBD,
YGDC, ZYAB, ZYAC, ZYAE, ZYDB,
ZYDC, ZYDE

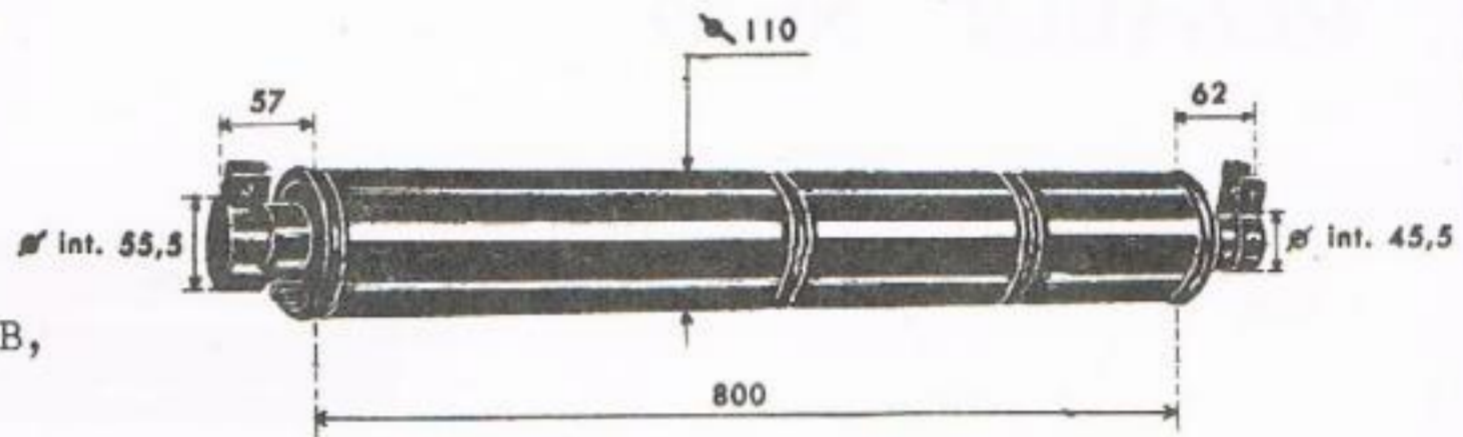

RENAULT N° 111

- Camions ADH, ADH-1,
ADH-D, ADJ, ADJ-D,
ADR, ADR-D, ADR-DA,
AGP, AGP-1, AGP-D,
AGR, AGR-D

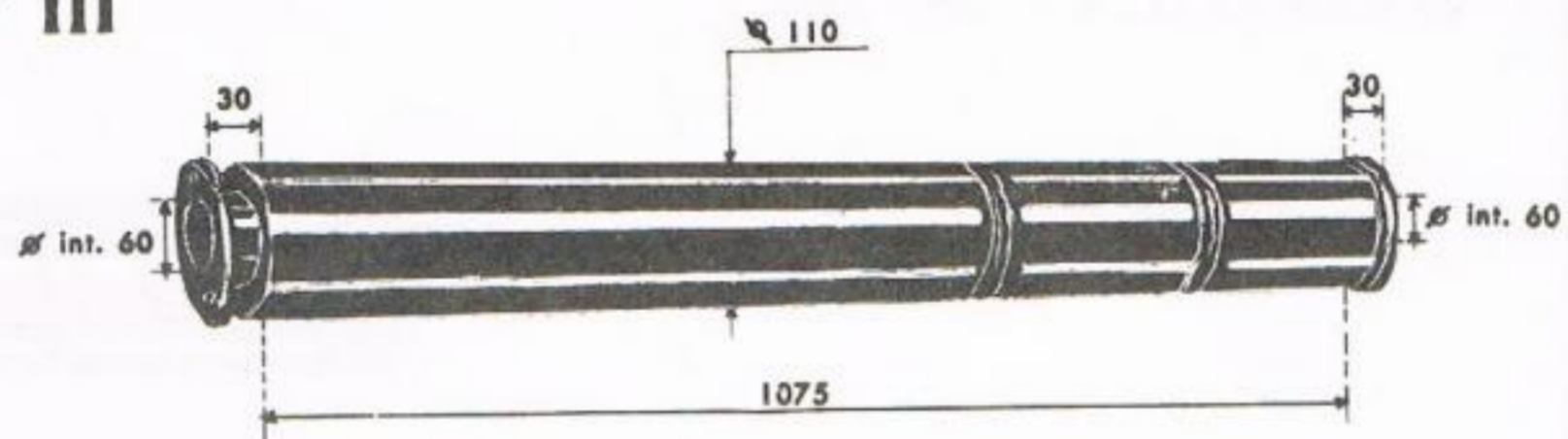

RENAULT N° 53

- Camionnettes 8 CV - YPB, YPC,
YPE

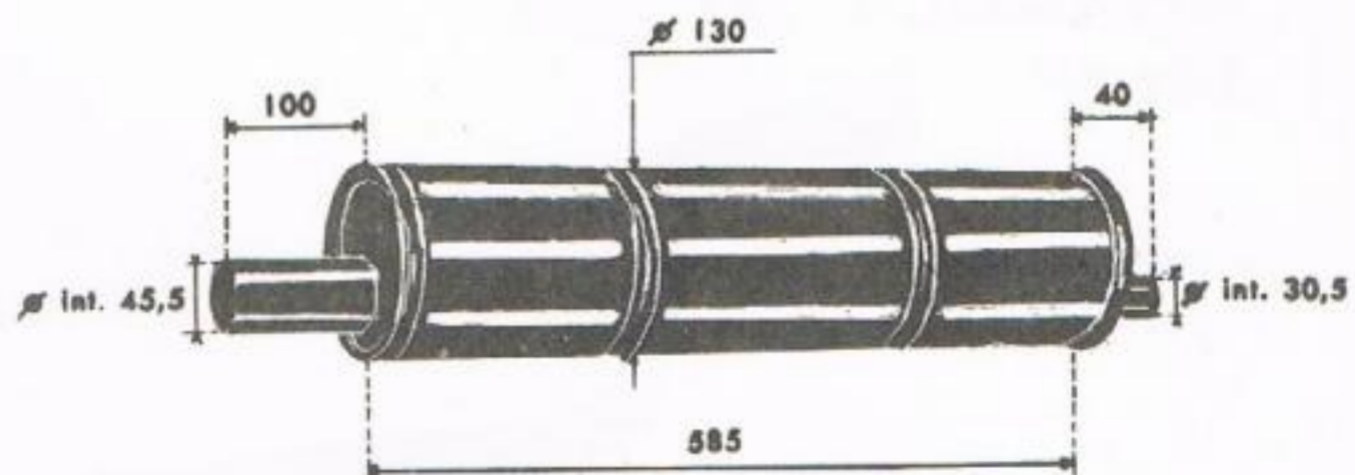

SILENCIEUX HG

Adaptables à

RENAULT N° 53

- Camionnettes 8 CV - ADV-1

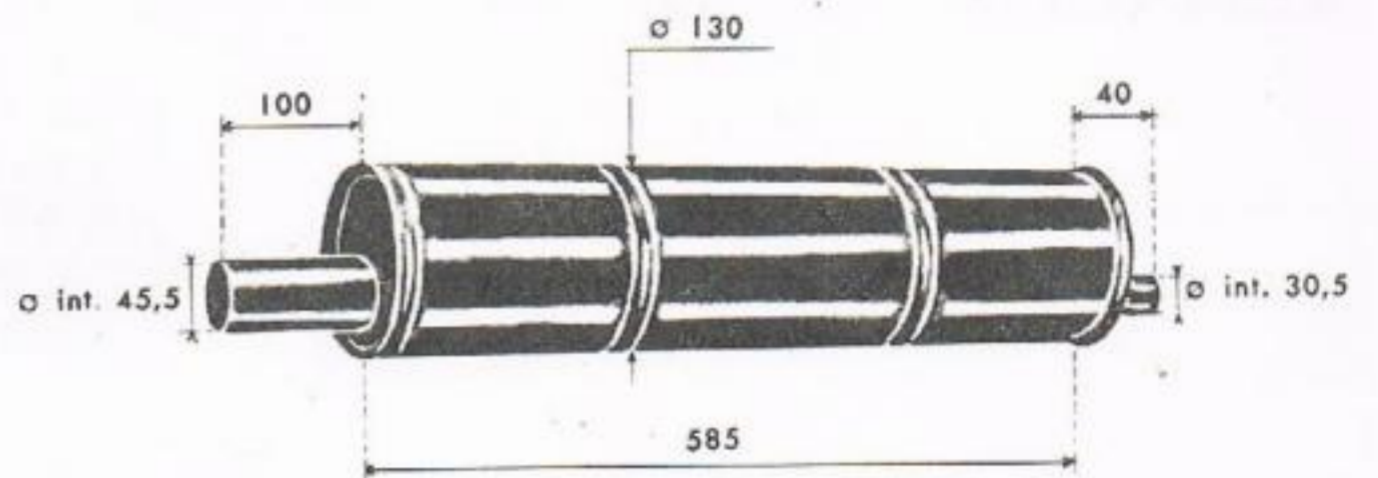

RENAULT N° 191

Tube AR

- Camionnettes 8 CV, ADV-1

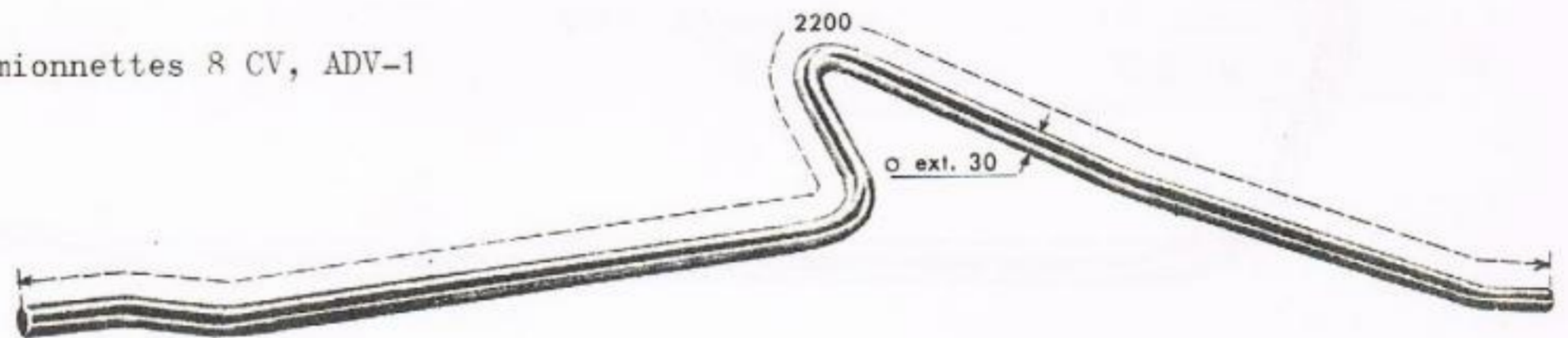

RENAULT N° 88

- Camionnettes et Camions 14 CV

ACZ-1, ADK-1, ADN-1, AFP-1,
AGC-1,2

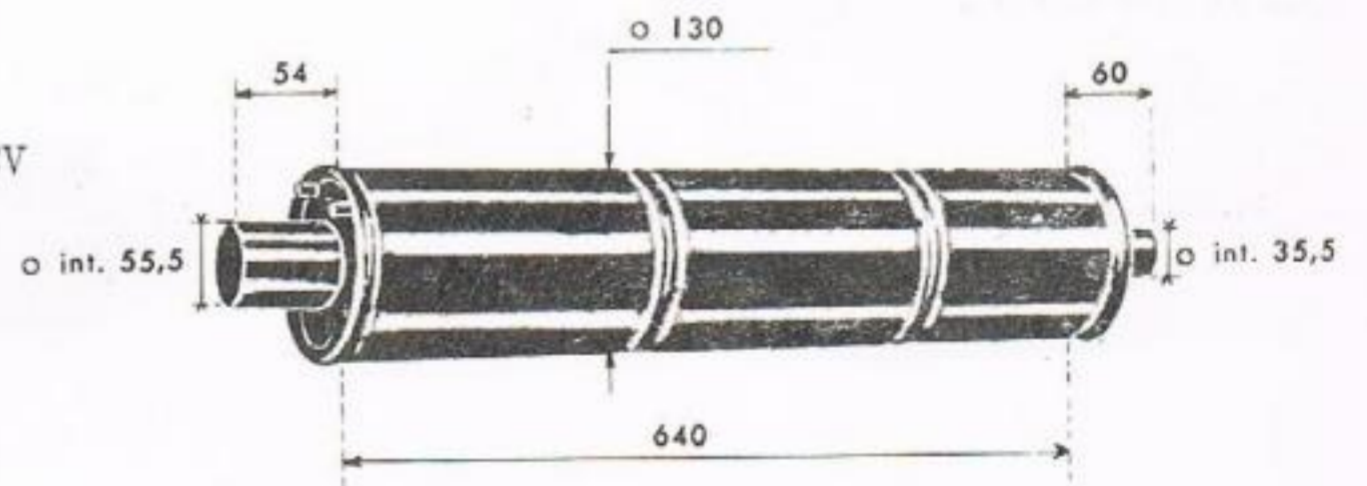

RENAULT N° 58

- Camionnette 14 CV
800kgs, ADZ-1

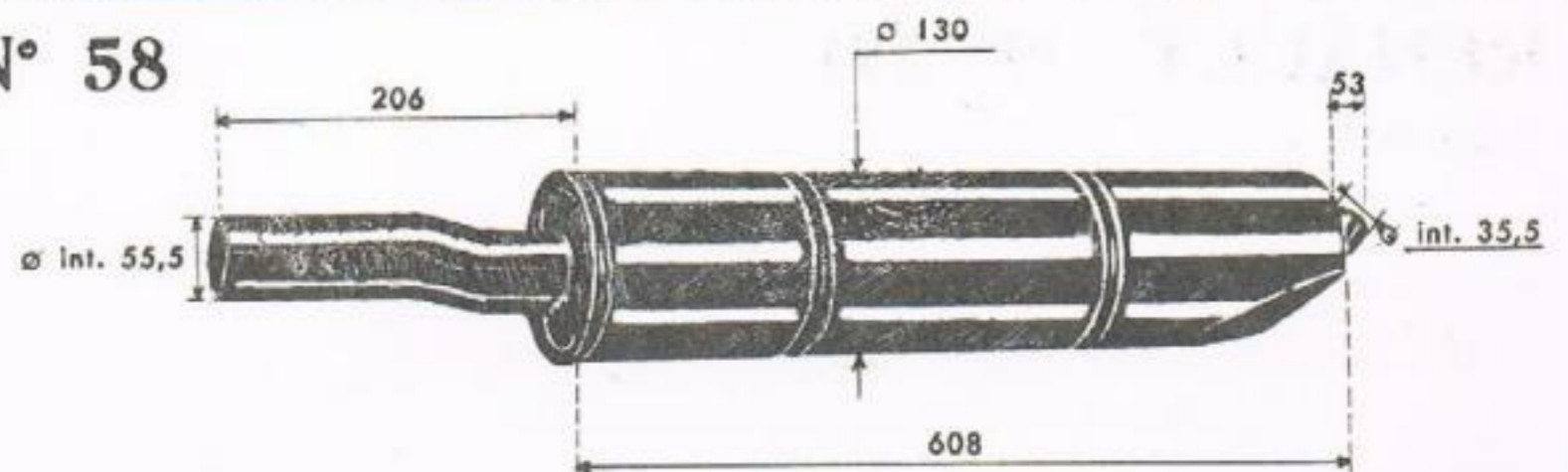

SILENCIEUX HG

Adaptables à

RENAULT N° 37

- Camionnettes et Camions 14 CV
AFB-2, AFP-2,3, AGS-3

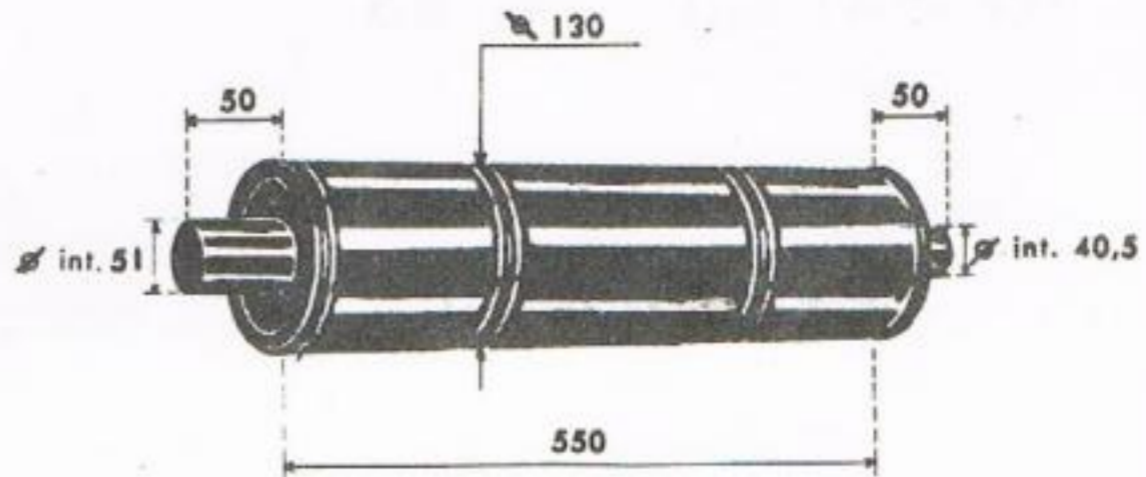

RENAULT N° 451

Tube AV

- Camionnettes et Camions 14 CV, AGC-3

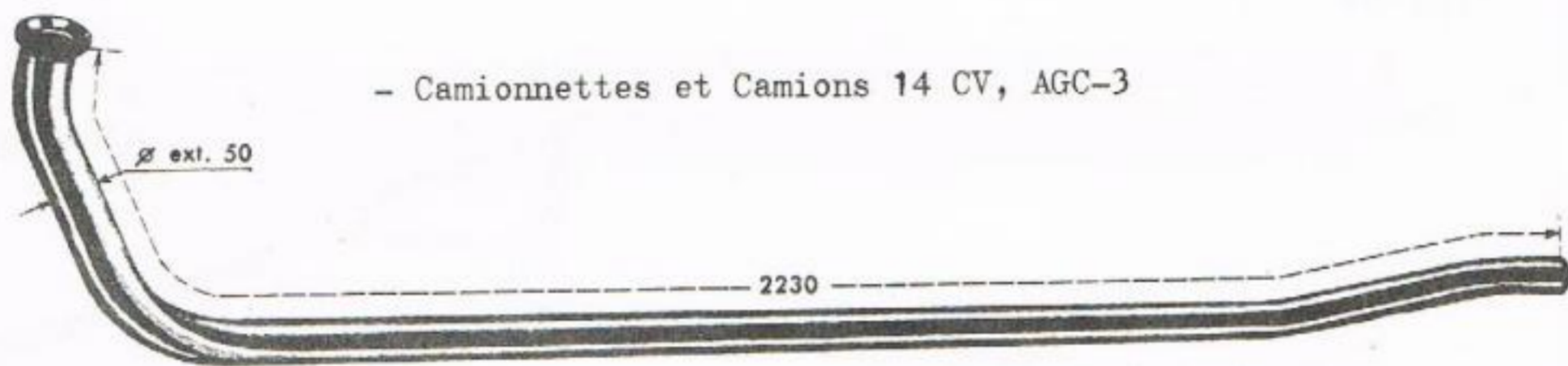

RENAULT N° 37

- Camionnettes et Camions 14 CV, AGC-3

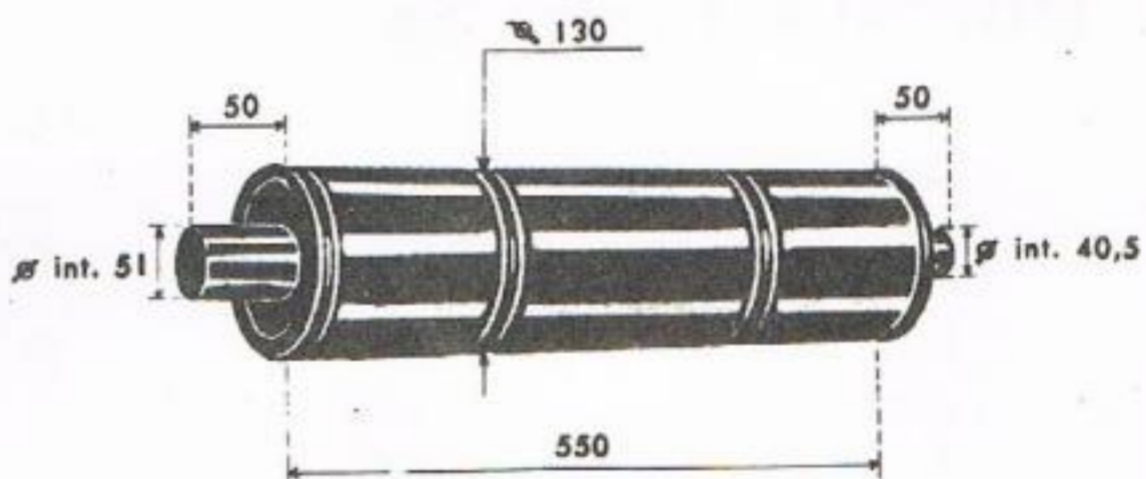

RENAULT N° 271

Tube AV

- Camionnettes et Camions 14 CV
AGC-L-1,2

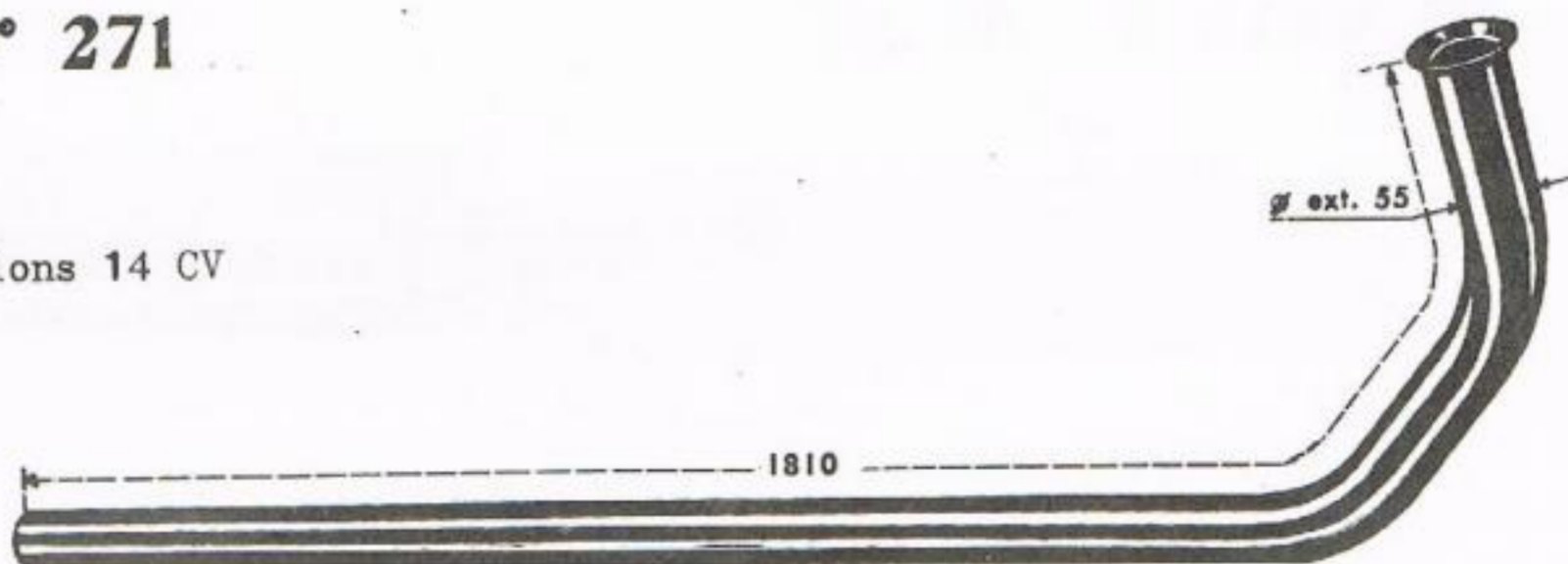

(Voir page N° 209, sil. N° 88)

SILENCIEUX HG

Adaptables à

RENAULT N° 88

- Camionnettes et Camions
14 CV, AGC-L-1,2

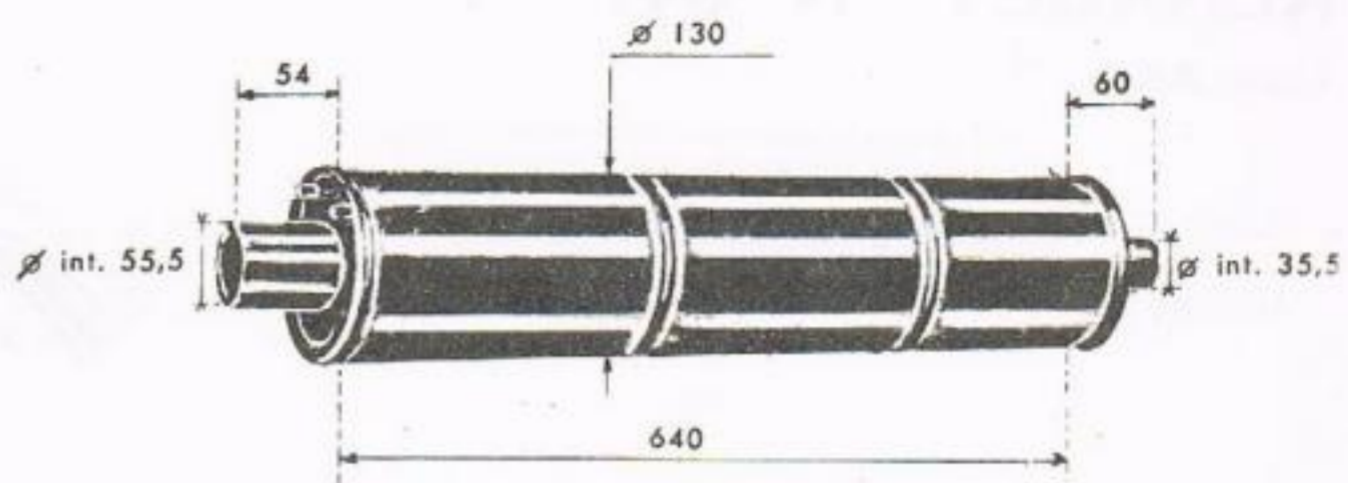

RENAULT N° 34

- Camionnettes et Camions 14 CV
AGS-1,2

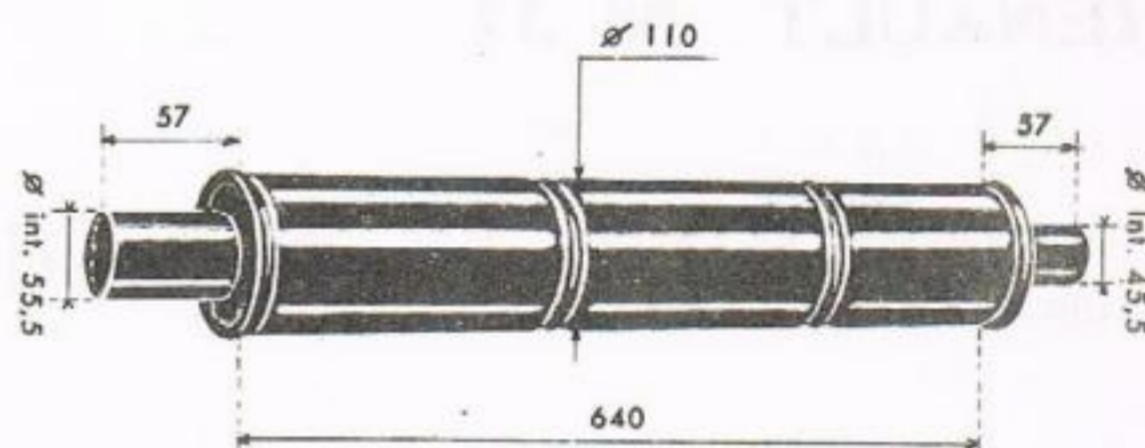

RENAULT N° 131

Tube AR

- Camionnettes et Camions 14 CV
AGS-1,2

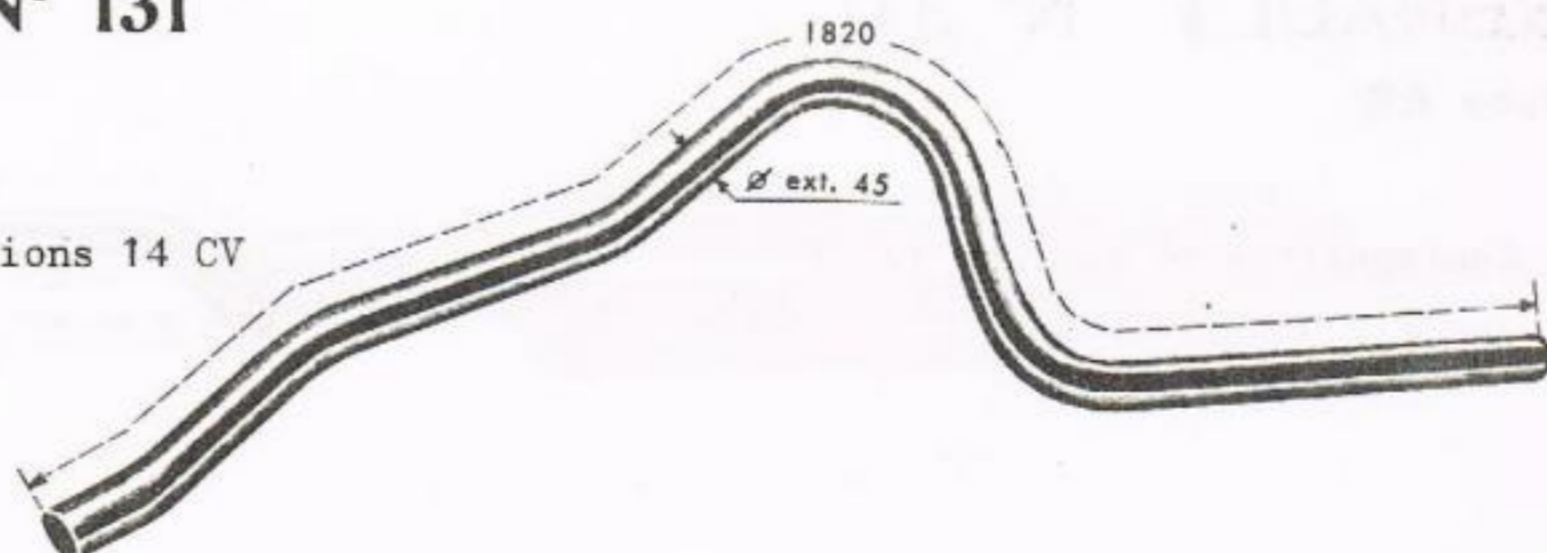

RENAULT N° 55

- Camionnettes et Camions 14 CV
AHN-2,3

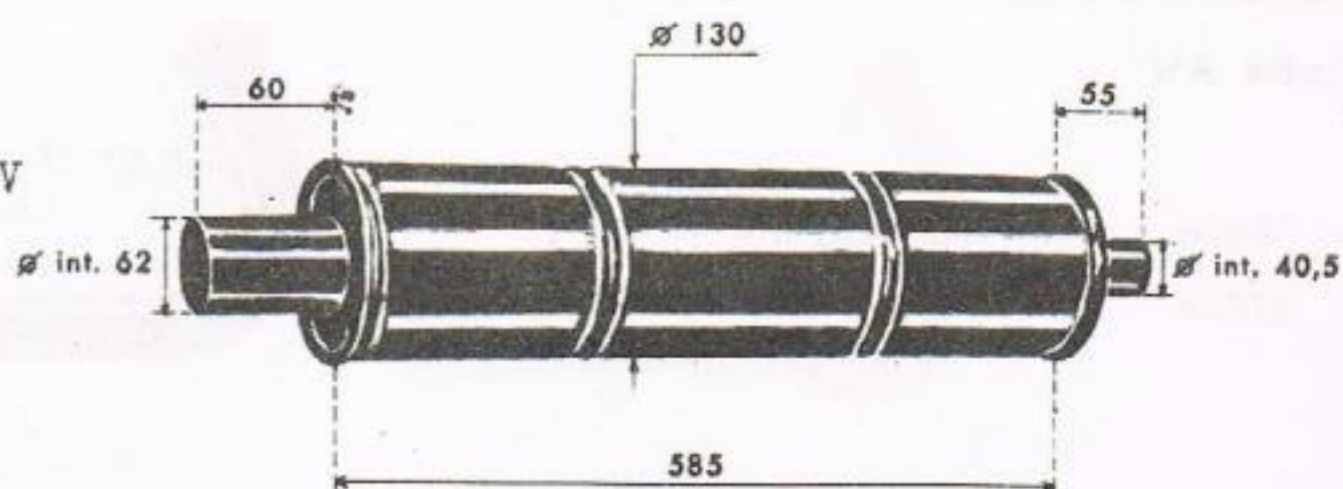

(Voir page N° 210, tube AR N° 341)

SILENCIEUX HG

Adaptables à

RENAULT N° 341

Tube AR

- Camionnettes et Camions 14 CV
AHN-2,3

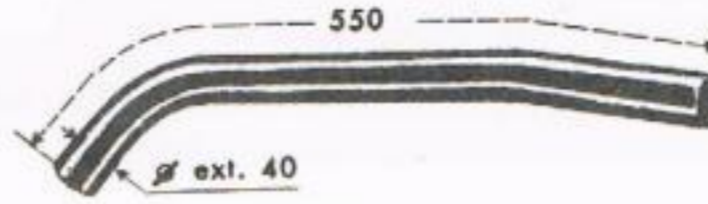

RENAULT N° 37

- Camionnettes et Camions 14 CV
AHS-1,2,3

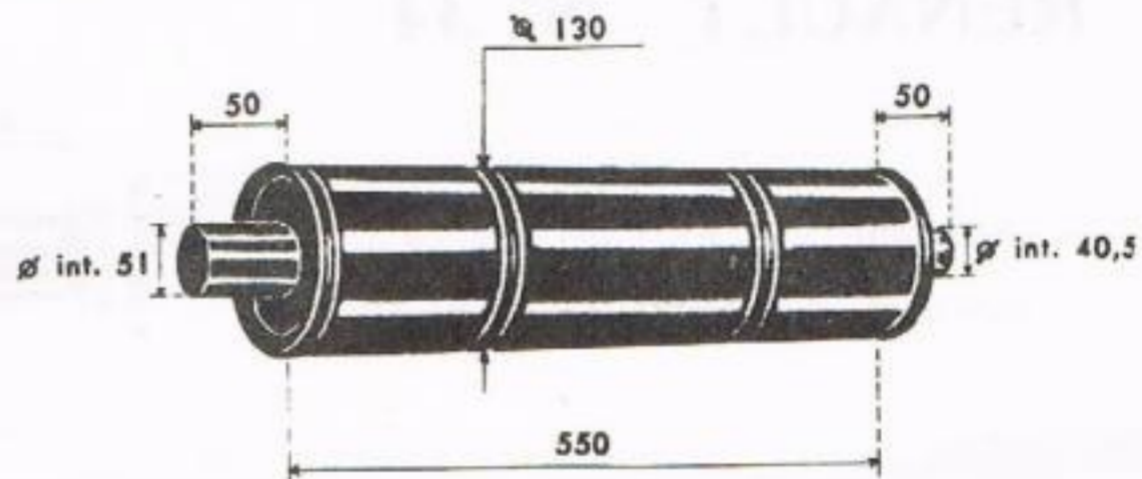

RENAULT N° 341

Tube AR

- Camionnettes et Camions 14 CV
AHS-1,2,3

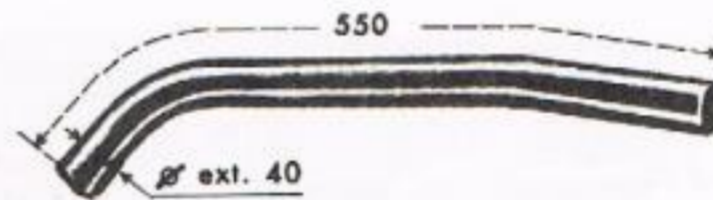

RENAULT N° 331

Tube AV

- Camionnettes et Camions 14 CV
AHS-4

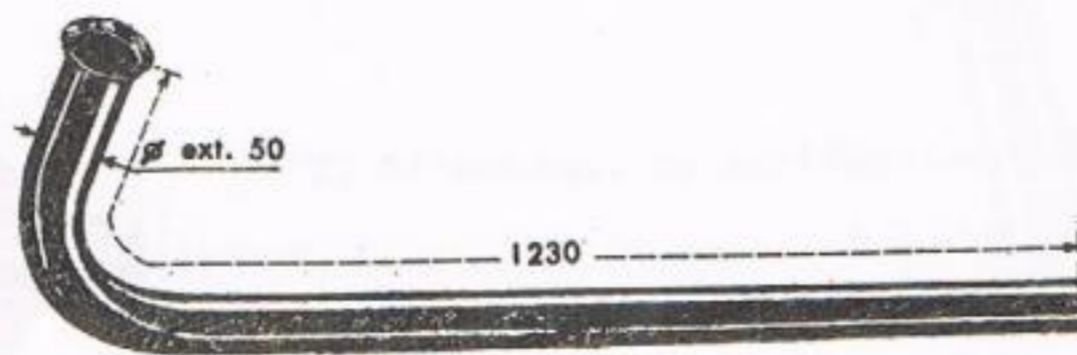

(Voir page 211, sil. N° 37, et tube AR N° 341)

SILENCIEUX HG

Adaptables à

RENAULT N° 37

- Camionnettes et Camions 14 CV
AHS-4

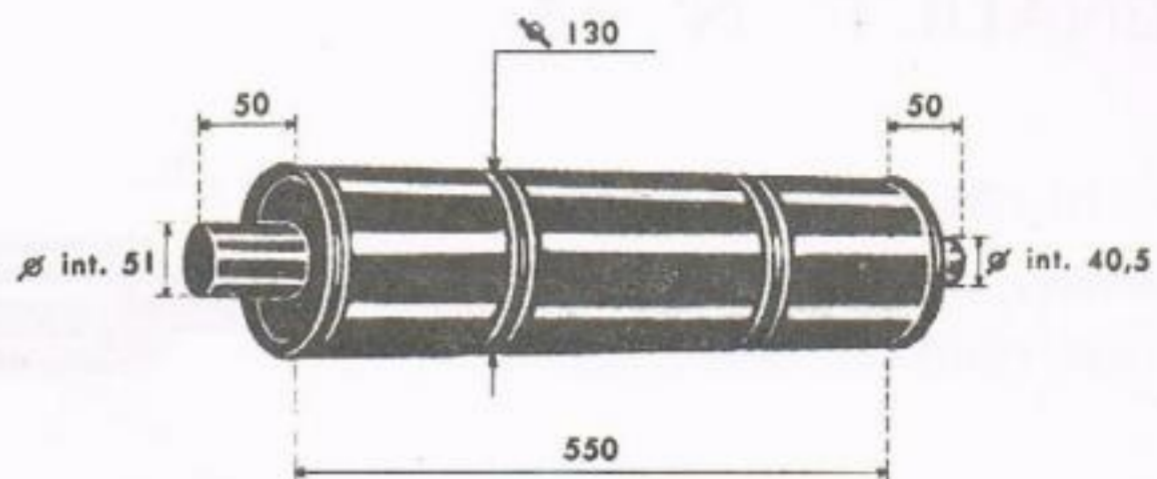

RENAULT N° 341

Tube AR

- Camionnettes et Camions 14 CV
AHS-4

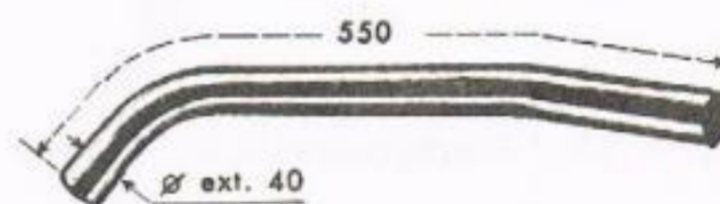

RENAULT N° 56

- Camionnettes 14 CV
800kgs - APR-1 2,3

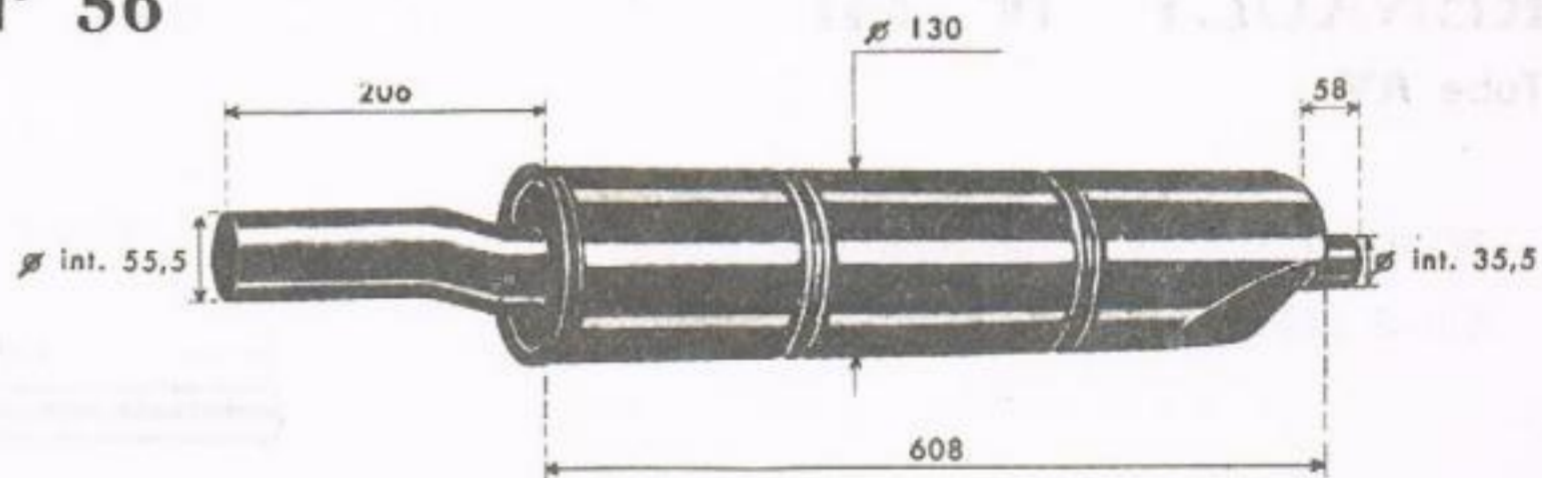

RENAULT N° 201

Tube AV

- JUVAQUATRE 6 CV, Fourgonnettes 300kgs
AGZ-1,2 - AHG-1 (1938/1940)

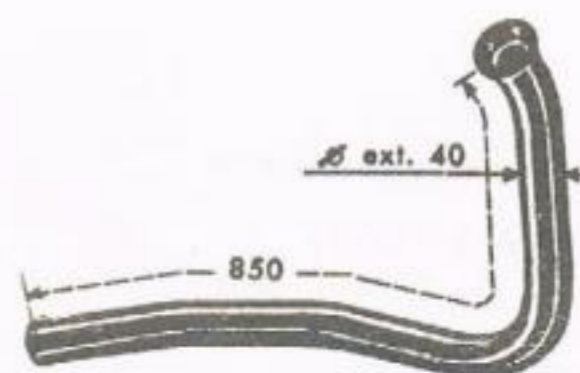

(Voir page 212, sil. N° 33, et tube AR N° 171)

SILENCIEUX HG

Adaptables à

RENAULT N° 33

- JUVAQUATRE 6 CV, Fourgonnettes
300kgs, AGZ-1,2 - AHG-1
(1938/1940)

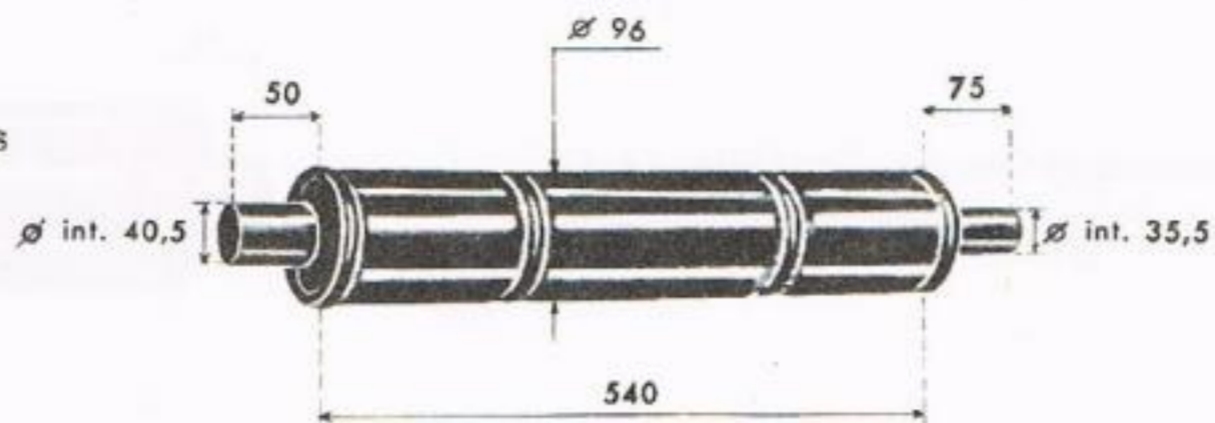

RENAULT N° 171

Tube AR

- JUVAQUATRE 6 CV, Fourgonnettes 300kgs
AGZ-1,2 - AHG-1 (1938/1940)

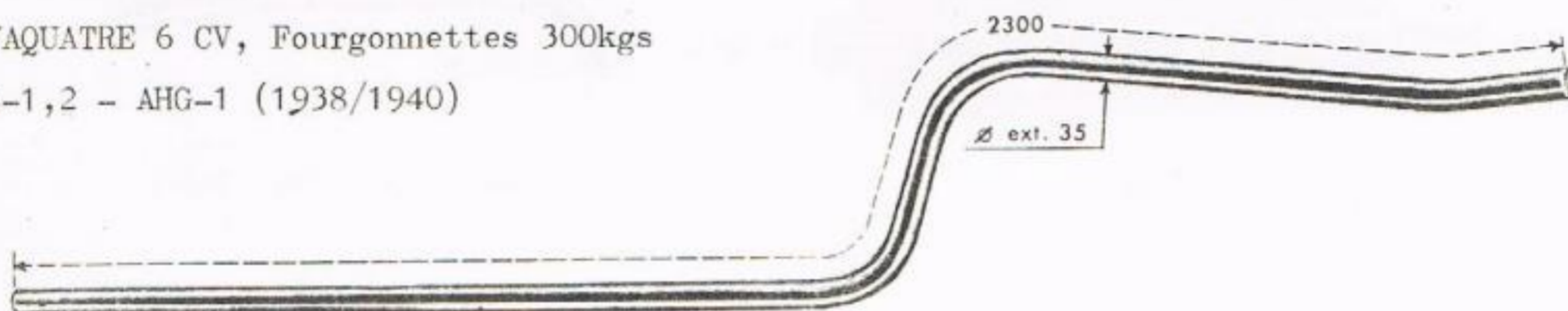

RENAULT N° 241

Tube AV

- JUVAQUATRE 6 CV, Fourgonnette 300kgs
AHG-2 (1945/1953)

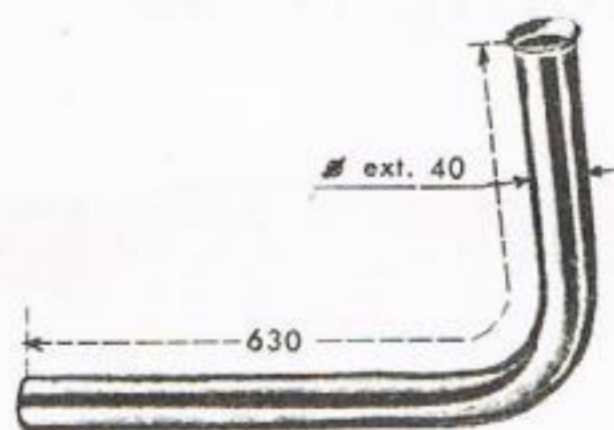

RENAULT N° 33

- JUVAQUATRE 6 CV, Fourgonnette
300kgs, AHG-2 (1945/1953)

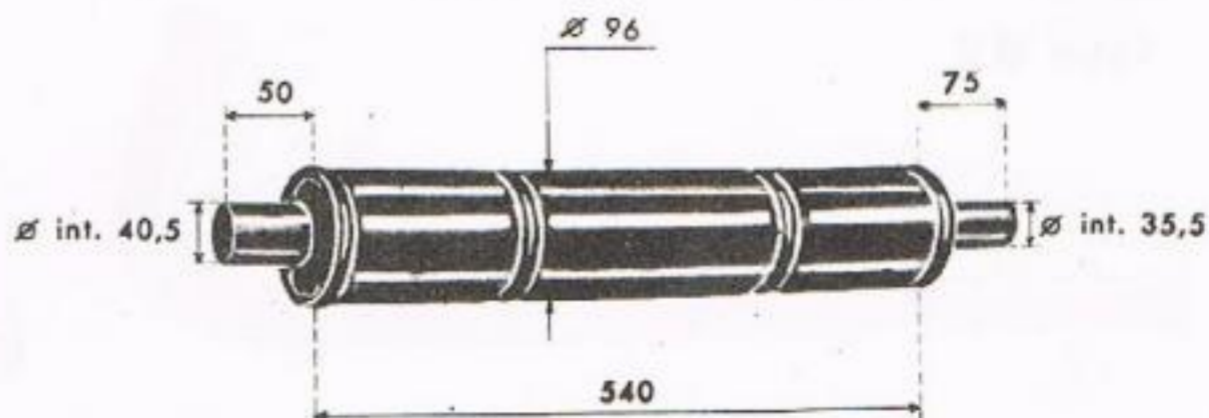

(Voir page 213, tube AR N° 181)